

# Providing QoS Guarantees in Broadband Ad Hoc Networks

Marek Natkaniec, Katarzyna Kosek-Szott, Szymon Szott, Andrzej Głowacz, and Andrzej R. Pach

*Department of Telecommunications, AGH University of Science and Technology, Kraków, Poland*

**Abstract**—This paper presents a novel QoS architecture for IEEE 802.11 multihop broadband ad hoc networks integrated with infrastructure. The authors describe its features, including MAC layer measurements, traffic differentiation, and admission control. The modules required by the network elements as well as their integration are also presented. Additionally, the paper presents results which validate its correct operation and prove its superiority over plain IEEE 802.11. The authors are convinced that the proposed solution will provide QoS support for a variety of services in future mobile ad hoc networks.

**Keywords**—*ad-hoc networks, QoS, IEEE 802.11 EDCA.*

## 1. Introduction

Mobile ad hoc networks (MANETs) are distributed wireless networks in which all nodes act as both terminals and routers. The deployment of MANETs is fast and effortless thanks to their autoconfiguration and lack of fixed connections. They already have multiple applications, especially in places where access to infrastructure is limited or unavailable. However, in the near future, MANETs coupled with infrastructure will allow pervasive, broadband Internet access. Special gateway routers will act as bridges connecting the ad hoc and infrastructure parts. This seems a promising solution for rural and developing areas where broadband infrastructure is unavailable. Therefore, MANETs are the focus of this paper.

When considering future networks it is important to take into account both broadband application requirements and user expectations. As a consequence, there is a need for networks to provide quality of service (QoS) support for such applications as video on demand, voice over IP, interactive entertainment, multimedia streaming, or peer-to-peer data exchange. There are several approaches which try to face this problem in MANETs. However, they lack appropriate traffic differentiation, scalability or a cross-layer approach. For these reasons they are not suitable to provide appropriate QoS.

In this paper the authors propose a service-oriented architecture for MANETs. This architecture provides a complex, cross-layer solution to the problem of QoS provisioning. Its goal is to provide end-to-end QoS in intra-MANET communication. This is accomplished by precise MAC layer measurements, traffic differentiation, traffic shaping, flexible signaling, admission control, bidirectional reservation, and resource management. Furthermore, the architecture

prospectively supports IPv6, making it suitable for deployment in the near future. The authors are confident that the proposed architecture will fill the gap in providing QoS in future MANETs.

The remainder of this paper is organized as follows. Section 2 presents related work and shows the limitations of current solutions. Section 3 describes the proposed QoS architecture. The details of QoS provisioning including traffic differentiation and measurements are explained in Section 4. The measurement results presented in Section 5 validate the most important part of the proposed architecture, QoS provisioning at the MAC layer. Finally, Section 6 concludes the paper and describes future work.

## 2. Related Work

In order to confront the proposed architecture with the state of the art in the field, the authors briefly present research related to QoS provisioning in MANETs.

QoS protocols for MANETs need to operate in a distributed manner, provide resource reservation, admission control, traffic differentiation, and dynamic regulation. There are several solutions for QoS support in ad hoc networks which aim to meet these requirements. The most known are SWAN (Stateless Wireless Ad Hoc Networks) [2] and INSIGNIA [3]. SWAN presents a stateless approach to QoS support. This model provides resource reservation, admission control and dynamic regulation in case of congestion. It considers two traffic categories: real-time and best-effort. SWAN's negotiation capabilities are very limited and optimized to operate in a pure ad hoc scenario. INSIGNIA is a reservation-oriented QoS framework which allows resource allocation, dynamic regulation, and per-flow management. Each node maintains soft-state reservations based on available resources in order to support adaptive services. To distribute QoS information, in-band signaling is used. The main drawback of INSIGNIA is its complex signaling and lack of scalability. Other QoS mechanisms for MANETs include CEDAR [9], FQMM [8], AQOR [10], courtesy piggybacking [7], and AAC [6]. An overview of selected protocols can be found in [4].

## 3. QoS Network Architecture

The proposed QoS architecture consists of two main logical units, the mobile node (MN) and the gateway (GW). The MN has a double role acting both as a user terminal

which provides QoS support to the end user, and as a router which forwards the traffic of neighboring nodes. The GW can provide connectivity with infrastructure, participate in admission control and dynamic regulation.

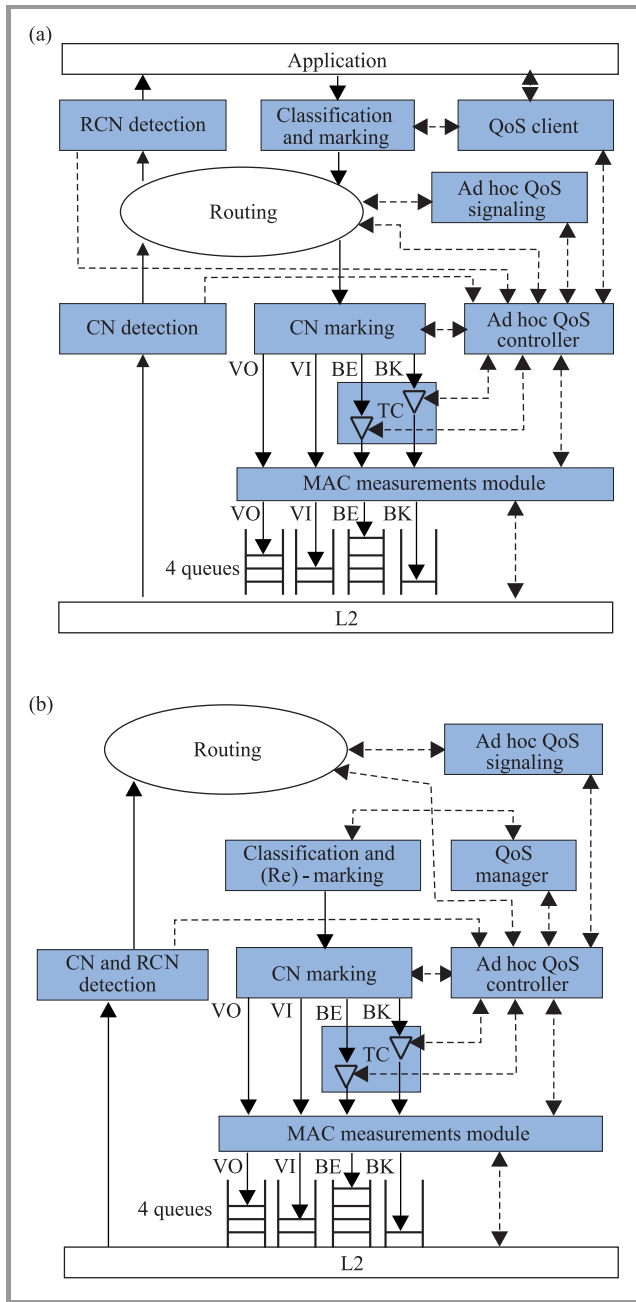

Fig. 1. QoS modules in mobile node (a) and gateway (b).

Figure 1 presents the proposed QoS modules (grey colour) in MN and GW. In this figure, the solid arrows correspond to data packet processing; the dashed arrows correspond to control information flow. End-to-end QoS resource management is supported through the interoperation of MN and GW. More specifically, this occurs through the interaction between the QoS client (QoSC) in the MN and QoS manager (QoSM) in the GW. QoSC retrieves the necessary QoS parameters from applications (through an API

and maps them to network QoS parameters. QoSC also performs per-flow end-to-end QoS signaling, controls the classification and marking module (which marks the traffic class and flow label fields in IPv6 headers), notifies the applications of the state of network interfaces, and performs the synchronization of network resource reservation. QoSM provides the same functionalities as QoSC but without the interface to the application layer.

The ad hoc QoS controller (AHQoS) is the central module in both MN and GW, which coordinates the work of the other modules. Through interaction with the results of the MAC measurements module (MMM) it determines the available resources in the wireless medium. The main responsibilities of AHQoS are: admission control in the ad hoc path, traffic control, reaction to congestion, and participating in resource management. If resources from higher priority access categories are available, AHQoS reallocates them to lower priority access categories in order to maximize network utilization.

Measurements of incoming and outgoing traffic are performed by the MMM. It provides AHQoS with information regarding bandwidth utilization, transmission delay, current transmission rate, frame statistics and idle intervals. The ad hoc QoS signaling (AHQoSSig) module is responsible for session establishment. This includes QoS negotiations as well as probing for available bandwidth and session setup between infrastructure and ad hoc or vice versa.

The IEEE 802.11 EDCA [1] function is used to provide traffic differentiation at the MAC layer. Additionally, to enhance traffic differentiation, the traffic controller (TC) module is used to shape lower-priority flows.

To make the architecture aware of overload situations, the congestion notification (CN) signaling mechanism is proposed. It is implemented with the use of three modules: CN marking (CNM), CN detection (CND), and receiver CN detection (RCND). CNM is responsible for setting certain bits (defined as CN bits) located in the Traffic Class field of the IP header of outgoing data packets. This happens when the target bandwidth of a given access category is exceeded. CND monitors incoming data packets. If it finds that the CN bit in a packet is set, the source of the traffic is notified. In the case of real-time traffic, the source should try to re-establish the session by sending a new probing request to the destination. As a result, the application will either adapt its rate or drop the session. In the case of non real-time traffic, the source should reconfigure its TC to shape this traffic. CNM is located in the data flow after CND. Therefore, if the CN bit is set, the congestion will not be discovered at the next node after the source node. This is a very serious problem if the next node is also the destination node. To assure the functionality of discovering violations in such a situation, RCND was introduced. It operates similarly to CND.

The GW is able to support the same functionalities as the MN, but does not interact with applications (since it works only at the IP layer and below) (Fig. 1b).

The routing module implements an ad-hoc routing protocol, AODV [11].

## 4. QoS Provisioning

QoS provisioning is achieved by traffic differentiation at the MAC layer. The proposed architecture utilizes the four traffic access categories of the IEEE 802.11 EDCA function. Thus, a finer service granularity and better cross-layer integration are achieved in comparison to related work. MAC layer measurements are fast and efficient thanks to driver implementation. It is assumed that all wireless devices work in promiscuous mode. This allows measurements with the use of a single wireless adapter, which is an additional advantage over literature, where usually two adapters are required.

### 4.1. Traffic Differentiation

The proposed traffic differentiation model extends SWAN to provide a finer service granularity. SWAN considered only two traffic categories, whereas in the proposed architecture four access categories are utilized. These classes are voice (VO), video (VI), best effort (BE), and background (BK). They are ordered by priority, based on their QoS requirements. They also correspond to the access categories of EDCA, which is responsible for traffic differentiation in channel access. Each access category has separate access parameters and a separate hardware priority queue (Fig. 1). Thanks to MAC layer traffic differentiation, the differentiation at the IP layer is simplified, compared to the literature.

To provide further separation of traffic and enable better resource control, each access category has an impassable bandwidth limit. Additionally, bandwidth can be re-allocated on-demand to ensure maximum network utilization. Unoccupied bandwidth of the high priority categories can be re-assigned to low priority ones. Classless traffic (e.g., traffic from stations not using the proposed architecture) is put into the BK category. This ensures interoperability with non-QoS stations.

Traffic shaping occurs in TC for BK and BE traffic. Shaping is not used for VO and VI categories, since it is unacceptable for sensitive multimedia traffic. In case of congestion, instead of shaping, a lower transmission rate with a different voice or video codec is negotiated. Traffic differentiation for these categories is further complemented by admission control performed by AHQoS.

### 4.2. MAC Layer Measurements

MAC layer measurements are crucial for QoS support in MANETs. They are performed by MMM, which is located in the driver between the IP layer and the wireless card firmware. This approach allows for fast and efficient operation on transmitted and received packets.

The authors propose a universal approach to implementing MAC layer measurements in mobile devices, which usually have only one wireless adapter. The SWAN approach is capable of capturing all IEEE 802.11 frames; however, it requires two wireless adapters: one for measuring and another for normal Tx/Rx operation. In the proposed architecture, the wireless adapter is set to promiscuous mode, which allows for concurrent transmissions and measurements using only a single wireless adapter. This is a significant advantage over SWAN. However, this approach does not allow the capturing of certain control and management frames. Therefore, a new PHY layer bandwidth estimation method was implemented.

The following parameters are measured:

- Per-category and overall average packet delay – the time between receiving a packet from the IP layer and the completion of the RTS-CTS-DATA-ACK exchange in EDCA.
- Per-category and overall bandwidth utilization – achieved by sensing the medium and constructing periodic statistics about bandwidth occupancy.
- Transmission rate – the currently chosen rate (wireless cards support multi-rate modes), required to evaluate available bandwidth.
- Number of stations – the estimated number of active stations in the neighbourhood, required to determine the contention between MNs in the wireless channel and to evaluate the available bandwidth.

Each access category is distinguished by its Traffic Class field in the IPv6 header, which allows per-category measurements. The measurements are periodically analyzed by AHQoS to adjust traffic shaping and to perform admission control decisions.

## 5. Measurement Results

The objective of the experiments presented in this section was to validate the most important part of the proposal (QoS provisioning at the MAC layer) and compare traffic differentiation in three different network configurations: IEEE 802.11 DCF, IEEE 802.11 EDCA, and the proposed architecture.

The measurement scenario is presented in Fig. 2. The wireless network consisted of four MNs and one GW equipped with WLAN cards set to ad hoc mode. These cards were based on the Atheros chipset and the madwifi driver [5]. The madwifi driver was modified to obtain correct EDCA operation in ad hoc mode. Missing QoS fields in certain control frames were added to allow the correct recognition of QoS capable stations. The wireless cards used HR/DSSS PHY with a constant rate of 11 Mbit/s. All possible interferences were avoided and there were no hidden stations. The testbed was implemented in an IPv6 environment.

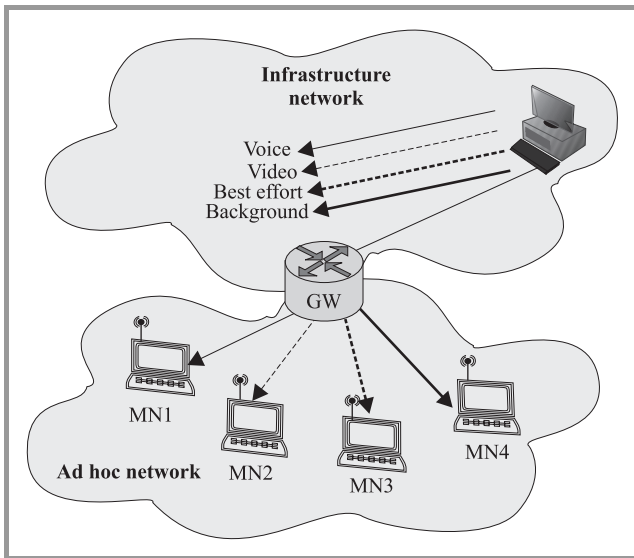

Fig. 2. Measurement scenario.

To provide the same conditions for each access category, the mgen tool was used to generate traffic. The traffic was generated in such a way so as to put the network in saturation. Three different configurations were considered and compared for their QoS capabilities: DCF, EDCA, and

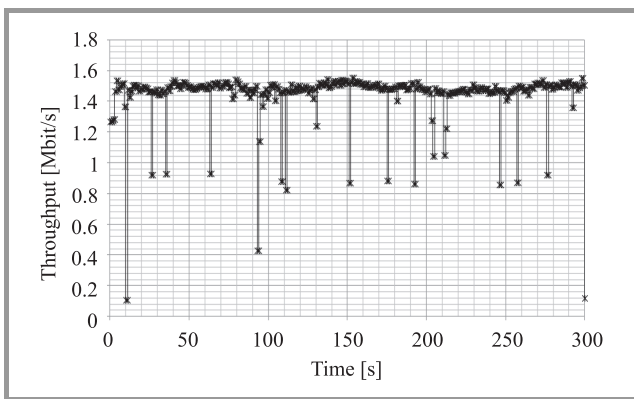

Fig. 3. Throughput for DCF.

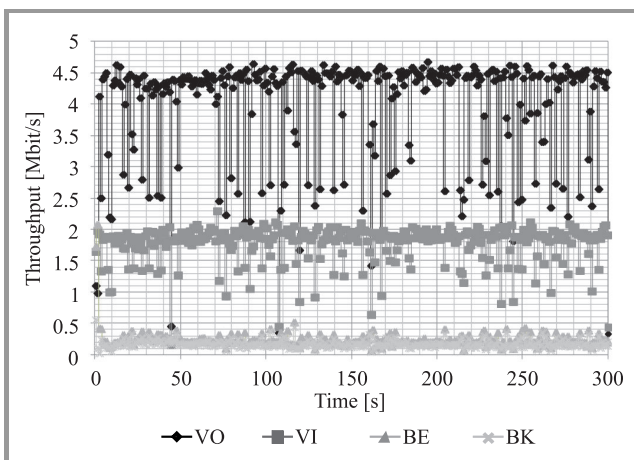

Fig. 4. Throughput for EDCA.

the solution proposed in this paper. The throughput values achieved when the DCF function was used are presented in Fig. 3. The throughput for each of the four ACs was the same, therefore only the average throughput values are illustrated in the figure.

The throughput values achieved when the EDCA function was used are presented in Fig. 4. The differentiation between traffic classes can be observed, however, higher priority traffic highly influences lower priority traffic. This is because we are not able to control the throughput level within each access category using only EDCA differentiation. VO and VI traffic have considerably degraded BE and BK traffic. Furthermore, the throughput of the VO and VI categories has high variation. This is because the network is saturated.

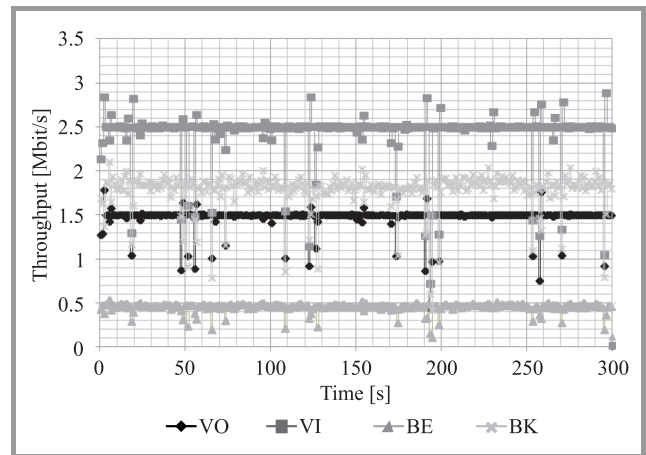

Fig. 5. Throughput for the proposed solution.

The throughput values achieved when the proposed solution was used are presented in Fig. 5. The following bandwidth utilization limits within each access category were assumed in our testbed: 1.5 Mbit/s for VO, 2.5 Mbit/s for VI, 0.5 Mbit/s for BE, and 1.8 Mbit/s for BK. The total sum of these limits did not exceed 95% of the maximum available network bandwidth, because additional control traffic was generated between MNs (e.g., beacons, probe request and response frames). The bandwidth limits for VO and VI were imposed through the use of the admission control mechanism implemented in the AHQoS. The limits for BE and BK were imposed through the use of traffic shaping mechanisms implemented in the TC module. Using the proposed approach, excellent traffic differentiation for all categories can be achieved. Additionally, the throughput level for each access category can be easily controlled and managed. Furthermore, thanks to the proposed solution the variation of throughput has decreased considerably. This also influences the achieved delay values (Fig. 8).

The delay values achieved using the three tested methods are presented in Figs. 6, 7, and 8. In the case of DCF the delay was at least 100 ms which can be considered acceptable for real-time traffic. However, as can be seen from Fig. 6, DCF does not allow traffic differentiation. In the case of EDCA the average delay for VI, BE and BK increased.

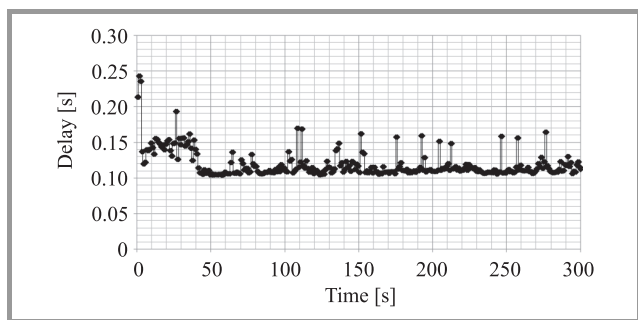

Fig. 6. Delay for DCF.

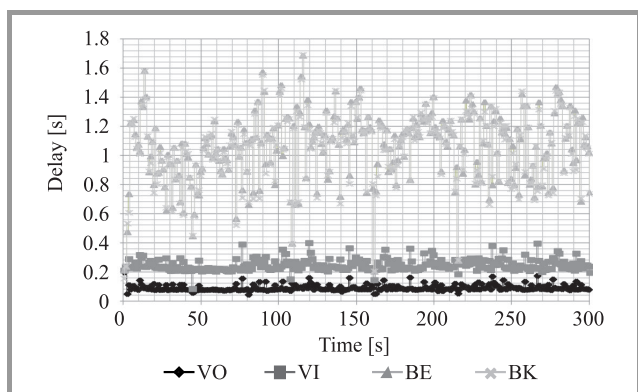

Fig. 7. Delay for EDCA.

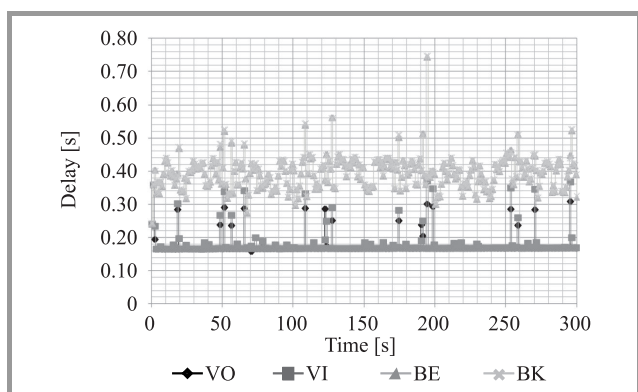

Fig. 8. Delay for the proposed solution.

Finally, with the use of the proposed solution the delay of these three ACs was improved.

## 6. Concluding Remarks

This paper describes an innovative approach to the problem of QoS support in mobile ad hoc networks. The proposed architecture has the following innovative features:

- QoS negotiations and traffic differentiation for the four IEEE 802.11 EDCA access categories with additional lower-priority traffic shaping.
- No requirements for per-flow or aggregate state information in the intermediate nodes (traffic classes are controlled locally using MAC layer measurements).

- Admission control performed only at the source node with the use of request/response probes which check the available per-class bandwidth on the path from the source to the destination.
- Reacting to overload situations with the use of efficient signaling techniques.
- Implementation of MAC layer measurements in WLAN cards.
- A modified driver which provides QoS capabilities in ad hoc mode.
- IPv6 support.

The initial validation of the proposed approach was presented in the form of measurements. These experiments showed that neither IEEE 802.11 without QoS support nor IEEE 802.11 with EDCA can provide adequate QoS provisioning. In the first case there was no traffic differentiation at all. In the second case, despite introducing traffic differentiation, there was no bandwidth separation between access categories (i.e., traffic of one category influenced traffic of other classes). In most cases this is insufficient to effectively provide QoS in multihop ad hoc networks. The proposed solution turned out to be the best approach with each access category achieving as much bandwidth as requested – there was no inter-category interference. Therefore, our unique solution makes it possible to achieve end-to-end QoS in an ad hoc network.

The presented architecture will hopefully meet user expectations regarding QoS guarantees in mobile ad hoc networks and provide them with ubiquitous and satisfactory, broadband Internet access. Future work will be focused on continuing the validation process in multihop environments (with different metrics) and enhancing the architecture to increase its performance.

## Acknowledgements

This work has been carried out under the Polish Ministry of Science and Higher Education grant no. PBZ/G018/T02/2007.

## References

- [1] "IEEE 802.11 Wireless LAN Medium Access Control (MAC) and Physical Layer (PHY) Specifications". IEEE Inc., New York, June 2007.
- [2] G.-S. Ahn *et al.*, "Supporting service differentiation for real-time and best-effort traffic in stateless wireless ad-hoc networks (SWAN)", *IEEE Trans. Mobile Comp.*, vol. 1, no. 3, pp. 192–207, 2002.
- [3] S. B. Lee *et al.*, "INSIGNIA: An IP-based quality of service framework for mobile ad hoc networks", *J. Parallel and Distrib. Comp., Wirel. Mobile Comput. Commun.*, special iss, vol. 60, no. 4, pp. 374–406, 2000.
- [4] M. Inayatullah, S. Ahmad, and A. Salam, "Optimized QoS protocols for small-sized manets", in *Proc. Int. Conf. Emerging Technol. IEEE ICET 2006*, Peshawar, Pakistan, 2006.
- [5] "MADWiFi – Multiband Atheros Driver for WiFi" [Online]. Available: <http://madwifi.org>
- [6] R. de Renesse, V. Friderikos, and H. Aghvami, "Cross-layer cooperation for accurate admission control decisions in mobile ad hoc networks", *IET Commun.*, vol.1, no. 4, pp. 577–586, 2007.

[7] W. Liu and Y. Fang, "Courtesy piggybacking: supporting differentiated services in multihop mobile ad hoc networks", in *Proc. 23rd Ann. Joint Conf. Comp. Commun. Soc. INFOCOM 2004*, Hong Kong, China, 2004, vol. 2, pp. 1273–1283.

[8] R. Braden, D. Clark, and S. Shenker, "Integrated Services in the Internet Architecture—an Overview", IETF RFC 1663, June 1994.

[9] P. Sinha, R. Sivakumar, and V. Bharghavan, "CEDAR: a core-extraction distributed ad hoc routing algorithm", in *Proc. Conf. Comp. Commun. INFOCOM'99*, New York, NY, USA, 1999, pp. 202–209.

[10] Q. Xue and A. Ganz, "Ad hoc QoS on-demand routing in mobile ad hoc networks", *J. Parallel Distrib. Comput.*, vol. 63, iss. 2, pp. 154–165, 2003.

[11] C. Perkins *et al.*, "Ad hoc On-Demand Distance Vector Routing", IETF RFC 3561, July 2003.



**Marek Natkaniec** received the M.Sc. and Ph.D. degrees in Telecommunications from the Faculty of Electrical Engineering, AGH University of Science and Technology, Kraków, Poland in 1997 and 2002, respectively. In 1997 he joined AGH University of Science and Technology. Currently he is

working as an assistant professor at the Department of Telecommunications, AGH University. His general research interests are in wireless networks. Particular topics include wireless LANs, designing of protocols, formal specification of communication protocols, modeling and performance evaluation of communication networks, quality of service, multimedia services provisioning and cooperation of networks. He is a reviewer to international journals and conferences. He has/had actively participated in European projects: MO-COMTEL, PRO-ACCESS, DAIDALOS I, DAIDALOS II, CONTENT, CARMEN, MEDUSA, HECTOR, FLAVIA as well as grants supported by the Polish Ministry of Science and Higher Education. Marek Natkaniec co-authored five books and over 100 research papers.

E-mail: natkanie@kt.agh.edu.pl

Department of Telecommunication  
AGH University of Science and Technology  
Mickiewicza Av. 30  
30-059 Kraków, Poland



**Katarzyna Kosek-Szott** received her M.Sc. and Ph.D. degrees in Telecommunications (both with honours) from the AGH University of Science and Technology, Kraków, Poland in 2006 and 2011, respectively. Currently she is working as an Assistant Professor at the Department of Telecommunications, AGH University of Sci-

ence and Technology. Her general research interests are focused on wireless networking. The major topics include wireless LANs (especially ad-hoc networks) and quality of service provisioning within these networks. She is a reviewer for international journals and conferences. She has been involved in several European projects: DAIDALOS II, CONTENT, CARMEN, FLAVIA as well as grants supported by the Polish Ministry of Science and Higher Education. She has also co-authored a number of research papers.

E-mail: kosek@kt.agh.edu.pl

Department of Telecommunication  
AGH University of Science and Technology  
Mickiewicza Av. 30  
30-059 Kraków, Poland



**Szymon Szott** received his M.Sc. and Ph.D. degrees in Telecommunications (both with honours) from the AGH University of Science and Technology, Kraków, Poland in 2006 and 2011, respectively. Currently he is working as an assistant professor at the Department of Telecommunications, AGH University. His professional inter-

ests are related to wireless networks (in particular: QoS provisioning and security of ad-hoc networks). He is a reviewer for international journals and conferences. He has been involved in several European projects (DAIDALOS II, CONTENT, CARMEN, MEDUSA, FLAVIA) as well as grants supported by the Ministry of Science and Higher Education. He is the co-author of several research papers and one book chapter.

E-mail: szott@kt.agh.edu.pl

Department of Telecommunication  
AGH University of Science and Technology  
Mickiewicza Av. 30  
30-059 Kraków, Poland

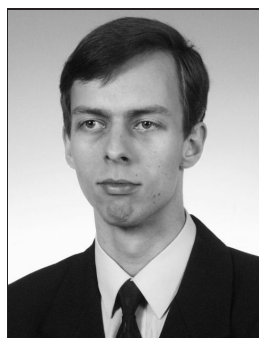

**Andrzej Głowacz** finished Ph.D. studies in Computer Science in 2006 and obtained Ph.D. in Telecommunications in 2007. Currently he is Assistant Professor in AGH University of Science and Technology. He has been working as an IT Expert in numerous commercial projects, grants of the Polish Ministry of Sci-

ence and Education and the European research projects: DAIDALOS, DAIDALOS 2, EuroNGI, EuroFGI, OASIS Archive, and GAMA. His main professional areas are: Wireless QoS, modern transport protocols, advanced Linux programming, network simulations, and multimedia

indexing systems. He is author of over forty scientific papers and technical reports, he also serves as a reviewer of several international journals and conferences.

E-mail: glowacz@kt.agh.edu.pl

Department of Telecommunication

AGH University of Science and Technology

Mickiewicza Av. 30

30-059 Kraków, Poland



**Andrzej R. Pach** received the M.Sc. degree in Electrical Engineering and the Ph.D. degree in Telecommunications from the University of Science and Technology, Krakow, Poland, in 1976 and 1979, respectively, and the Ph.D.Hab. in Telecommunications and Computer Networks from the Warsaw University of Technology in 1989.

In 1979, he joined the Department of Telecommunications at the University of Science and Technology, where he is

currently a Professor and Chair. He spent his sabbatical leaves at CNET, France and University of Catania, Italy. He is the Vice-President of the Foundation for Progress in Telecommunications and serves as a chairman of the IEEE Communications Society Chapter. He has been a consultant to governmental institutions and telecom operators in modern telecommunication networks. His research interests include design and performance evaluation of broadband networks, especially quality of service and network performance of access networks and wireless LANs. He has/had actively participated in COST, Eureka Celtic, and FP European programs (ACTS, ESPRIT, IST, ICT, and Security). He co-authored more than 200 publications including 6 books. He served as a technical editor to IEEE Communications Magazine and is an editor-in-chief to Digital Communications – Technologies and Services. He has also been appointed as an expert in Information and Communications Technologies by the European Commission.

E-mail: pach@kt.agh.edu.pl

Department of Telecommunication

AGH University of Science and Technology

Mickiewicza Av. 30

30-059 Kraków, Poland