

A Detector of Sleep Disorders for Using at Home

Piotr Przystup, Adam Bujnowski, Jacek Rumiński, and Jerzy Wtorek

Department of Biomedical Engineering, Gdańsk University of Technology, Gdańsk, Poland

Abstract—Obstructive sleep apnea usually requires all-night examination in a specialized clinic, under the supervision of a medical staff. Because of those requirements it is an expensive and a non-widely utilized test. Moving the examination procedure to patients' home with automatic analysis algorithms involved will decrease the costs and make it available for larger group of patients. The developed device allows all-night recordings of the following biosignals: three channels ECG, thoracic impedance (respiration), snoring sounds and larynx vibrations. Additional information, like patient's body position changes and electrodes' attachment quality are estimated as well. The reproducible and high quality signals are obtained using the developed and unobtrusive device.

Keywords—ECG, larynx vibration, sleep apnea, snoring sound, thoracic impedance.

1. Introduction

Sleep affects daily functioning and physical and mental health in many ways. During sleep body stays inactive but brain and other internal organs work continuously. Sleep is a relatively complicated and a repetitive activity and it is determined by many factors, i.e. body or organs activities. Thus, it can also be deprived by many factors.

The normal course of sleep can be divided into so called sleep phases (stages), which are recognized using a set of biosignals measurements [1]. When evaluating sleep disorders by abnormal sleep phases sequence recognition an electroencephalography (EEG) is necessary measurement technique. Sleep phases are recognized by analyzing electroencephalography, electrooculography (EOG), electromyography (EMG) data. The most advanced systems record at least three channels of EEG. In some circumstances, the actigraphy is utilized instead of EEG. This technique is widely accepted when diagnosing children [2].

Sleep can be affected by different types of disorders. Their detailed description is available in The International Classification of Sleep Disorders, Revised, Diagnostic and Coding Manual [3]. It is estimated that at least 75% of all adults suffer or will suffer from different diagnosable forms of sleep disorders. The most widespread sleep disorders include insomnia, sleep apnea (obstructive, central and complex or mixed), hypopnea, restless legs syndrome, narcolepsy, and idiopathic hypersomnia. Apnea is usually defined as airflow cessation for more than ten seconds. Hypopnea is recognized when reduction in thoraco-abdominal

movement is greater than 50% and lasts at least ten seconds. It is also diagnosed if a reduction in respiratory airflow lasts longer than ten seconds and is accompanied by a decrease of oxygen blood saturation higher than 4%.

Insomnia debilitates no fewer than 14% of Americans, while obstructive sleep apnea afflicts 10% of them. Moreover, it is also known that about 40% to 60% of people suffering from heart failure have problems with central sleep apnea. It is proven that untreated obstructive sleep apnea leads to obesity, stroke, hypertension, congestive heart failure, myocardial infarction and results in significant morbidity and mortality [4].

Above mentioned sleep disorders have essential impact on human's health. Therefore, there is active research aimed at development of new methods for diagnosing and treating of sleep apnea.

There are several techniques utilized in evaluation of obstructive sleep apnea. Polysomnography is considered as gold standard for the assessment of sleep [5]. At least seven signals (parameters) are recorded: respiratory activity, EEG, EOG, chin electromyography (chEMG), electrocardiography (ECG), airflow, and blood oxygen saturation (SaO₂) [5]. A trained person using a dedicated equipment performs and supervises all measurements. A diagnosed person has to sleep overnight in a special laboratory (usually in a specialized clinic).

However, it is considered that sleep evaluation at home might provide a more realistic appraisal of breathing disorders. Moreover, measurements can be performed for more than one night and therefore a size of collected data is bigger and probably more valuable. Due to these characteristics, a great number of portable devices dedicated to sleep quality evaluation at home have been developed, e.g. [6]. In general, these devices record different signals or signals sets and can be performed by examined person itself. There are many of different devices on the market devoted for out-of-center testing using similar methodology as for polysomnography. It follows from the fact that there is a great necessity to move polysomnographic-like examinations from the clinics to home however, preserving quality of examination. A common feature of these devices and methods is a reduced number of the measured signals. Thus, it may be expected that a sensitivity and specificity of such examinations can be reduced. In order to achieve a comparable quality of examination to the polysomnographic one a more advanced data analyzing methods are utilized or new type of measurements are proposed. During last twenty years higher interest is observed in studies utiliz-

ing an actigraphy in free-living environments [7]. Usually, the actigraphy unit uses a single sensor, typically based on an accelerometer.

One-signal approach has been also verified using recordings of ECG or SaO₂ [8]. However, a basic drawback of such methods is impossibility to differentiate between sleep and conscious states.

Currently available methods and devices can be categorized into groups based on a number of monitored processes. The most sophisticated enable examinations of activities inherent to: sleep (brain), heart, gas exchange (pulse oximetry), body position, and respiration/breathing effort [9].

Sleep phases are mainly recognized by analyzing electroencephalography data. The most advanced systems record at least three channels of EEG. In some propositions, the actigraphy technique is utilized instead of EEG. This technique is widely used when diagnosing children [2].

Cardiac activity evaluation is typically achieved using ECG. At least one measurement lead (not necessarily a standard one) is utilized. Information on cardiac activity could be also estimated using tonometry, plethysmography, or using pulse oximetry. In pulse oximetry a sensor is placed on a highly vascularized part of the diagnosed person's body, e.g., finger, ear lobe.

Oxygen transport to blood is commonly evaluated using a widespread and known pulse oximetry technique [10].

The body position is mainly determined by analyzing recorded video sequences [5].

The respiratory effort is considered as an attempt to respire. Typically, it can be measured by means of inductance plethysmography or resistive belts.

Finally, respiration is measured using a sensor of nasal pressure or thermal sensor. To increase a reliability of this measurement both sensors can be used simultaneously.

Recently proposed methods and devices are typically based on monitoring of a reduced number of above-mentioned signals (processes). Moreover, intensive studies are performed in order to detect apnea episodes basing only on a single signal records, e.g., ECG, pulse oximetry or actigraphy [7].

The main goal of this paper is to present the results of the research on a new device development allowing simultaneous measurement of appropriate signals for analysis of sleep disorders using a limited set of connections attached to the diagnosed person.

2. Methods and Materials

In the presented study the experimental device has been designed. This section will describe the developed hardware and software for the measurement procedure.

2.1. The Concept

The device should be capable for all-night measurement of following biosignals: three channel ECG, thoracic impedance, larynx vibrations, and snoring sounds. Ad-

ditionally, oxygen blood saturation should be introduced. The testing procedure should allow performing all measurements at home. This will allow for moving part of the diagnostic procedures from specialized clinics to patients home. It will reduce costs (e.g., related to stay in hospital, participation of medical staff) and will provide a better comfort for diagnosed person. The number of electrodes and sensors, which will be connected to the patient, should be minimized in order to provide comfortable conditions during the study. The collected data should be stored on the memory card for further analysis on external device. The real-time transmission of measured biosignals should be possible. Since the device will be battery powered, energy saving aspects should be taken into consideration as well.

2.2. Hardware Description

Simplified block diagram of the proposed diagnostic device has been presented in Fig. 1 [11].

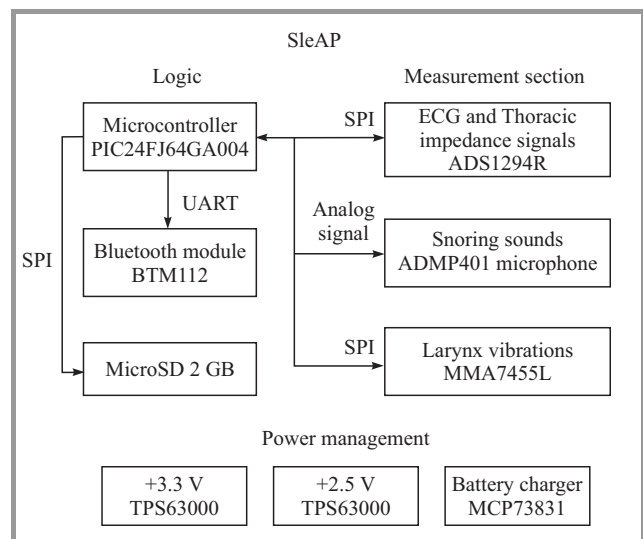

Fig. 1. Simplified block diagram.

Lithium-polymer battery with capacity around 1000 mAh has been used to power the device. Charging process is controlled by MCP73831 integrated circuit from Microchip. It has a built-in thermal shutdown and shorted input protections. Moreover, additional circuit has been added to protect against excessive battery discharge. It is possible to use USB interface to charge the battery using microUSB connector.

From power supply point of view two device main parts could be distinguish: the digital part with 3.3 V voltage level and the analog part with 2.5 V voltage level. Both voltages are generated using TPS63000 chip from Texas Instruments. It's a single inductor, buck-boost converter with efficiency up to 96% in miniature package (3.25 × 3.25 mm).

The main part of the device is 16-bit microcontroller PIC24FJ64GA004 from Microchip. It is a low power de-

vice with 64 KB program memory and a large set of remappable peripherals.

MicroSD Flash card is used for storage of registered biosignals. 2 GB card has been used with the FAT file system implemented. Serial Peripheral Interface (SPI) has been used for communication between the processor and the memory card. According to the performed analysis and experiments whole-night records contain about 250 MB of data. Therefore, it's possible to use the device for several nights, without memory card changing.

Additionally, all the recorded signals can be transmitted in real-time to an external device, like PC or a smartphone, using the Bluetooth interface. The device is equipped with BTM112 Bluetooth module made by Rayson company. Universal Asynchronous Receiver and Transmitter (UART) interface is utilized for communication between the module and the processor. Since the module is not equipped with an antenna, an external PCB antenna has been used. The authors have chosen small size (15 × 5.7 mm) 2.4 GHz PCB antenna offered by Texas Instruments. It requires 50 Ω source to be connected. To fulfill this requirements impedance matching π filter presented in Fig. 2 has been designed and implemented [12].

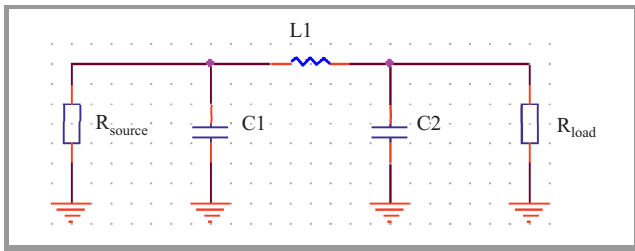

Fig. 2. Impedance matching π filter.

First of all the loaded quality factor $Q = 3$ had chosen. It needed to fulfill Eq. (1).

$$Q \geq \frac{1}{2} \sqrt{\frac{R_{SOURCE}}{R_{LOAD}}} - 1. \quad (1)$$

Since the load and source impedance are equal, the simplified formulas for capacitance and inductance values, Eqs. (2)–(6) can be used:

$$B_{C1} = \omega C1, \quad (2)$$

$$B_{C2} = \omega C2, \quad (3)$$

$$X_{L1} = \omega L1, \quad (4)$$

$$B_{C1} = B_{C2} = \frac{Q}{R_{LOAD}}, \quad (5)$$

$$X_{L1} = 2QR_{LOAD}(1 + Q^2). \quad (6)$$

As a result, the $L1 = 2 \text{ nH}$, $C1 = C2 = 3.9 \text{ pF}$.

The measurement section main part is based on ADS1294R integrated circuit from Texas Instruments. It is a low-power, 4-channel, 24-bit analog front-end for biopotential measurements. Built-in ECG features like Right leg drive (RLD)

amplifier, lead-off detector, pacemaker signal detector and integrated impedance measurement circuit make it an ideal solution for battery-powered medical devices. To reduce bill of materials cost and power consumption, internal clock and reference voltage are used. Since the proposed device is a mobile therefore, it could be exposed on mechanical vibrations. All the decoupling components located close to the chip analog part of this are either tantalum or EIA class 1 capacitors with C0G or NPO dielectric, which are non-ferroelectric. EIA class 2 and class 3 dielectric (e.g., X7R, X5R, Y5R, etc.) are ferroelectric. Those can have some piezoelectric properties, which can appear as an electrical noise coming from capacitor, which is strongly undesirable effect, especially in analog circuit part.

Reference voltage has been set to 2.4 V. ADS1294R has built-in amplifier at the input stage with programmable gain. Setting gain to 6 make the device compliant with ANSI/AAMI EC13 standard in case of input dynamic range ($\pm 5 \text{ mV}$ signal with $\pm 300 \text{ mV}$ offset) [13].

As mentioned before, the device is able to register three ECG leads (equivalent to Einthoven system). Electrodes are placed as presented in Fig. 3. Two of the leads are actually measured in analog domain, third is derived arithmetically, based on previous ones.

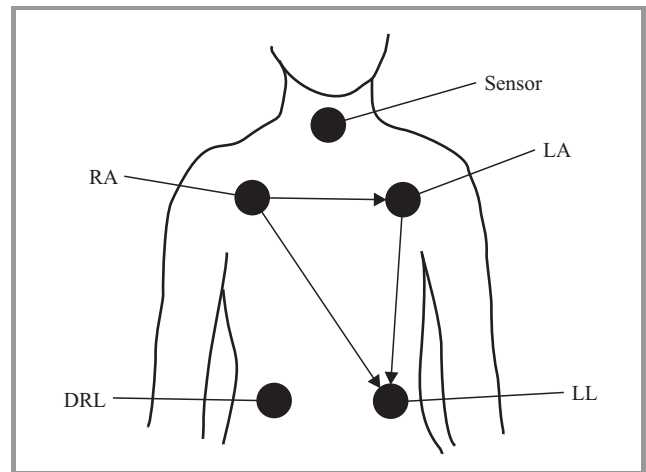

Fig. 3. Placement of the electrodes and additional sensor: RA – right arm, LA – left arm, LL - left leg, DRL – driven right leg.

The proposed device allows the lead-off detection. It could be useful to verify if all the electrodes are connected to the person's body properly. The detection method basic principle is based on injecting an excitation signal to the channel, and check it's response to determine whether the electrode is connected properly or not.

It is possible to use direct or alternating current as an excitation signal. In the proposed device a DC signal is used. Internal current source/sink is used in configuration showed below (Fig. 4).

Current magnitude has been set to 6 nA. In case of poor contact or no contact between the electrodes and patients body, current source/sink will saturate the channel (no connection) or offset will be visible (poor connection). Built-in

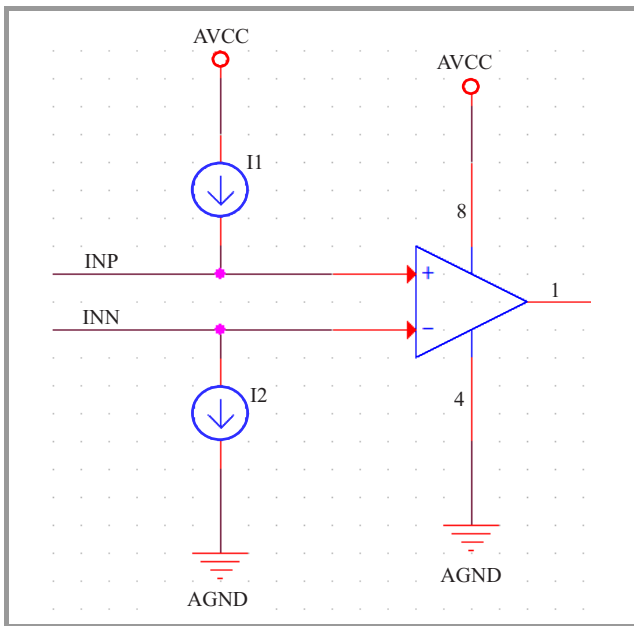

Fig. 4. DC lead-off detection.

comparators could be used for constant input voltage monitoring. It is worth to say, that using the DC lead off detection will add a small offset to the measured data even if both electrodes are connected properly.

Respiratory signal is measured using impedance method. Thoracic impedance is recorded using two-electrode method (Fig. 5). This means that the same electrodes are used for applying alternating current and measuring voltage across the body. The presented solution is worse than 4-electrodes method since the resistivity of electrode connections and leads has an impact on measurements results. However, the decreased number of electrodes has a positive influence on patient's comfort during the all-night study. In fact, it is possible to use the same electrodes for impedance measurements, which are used for ECG.

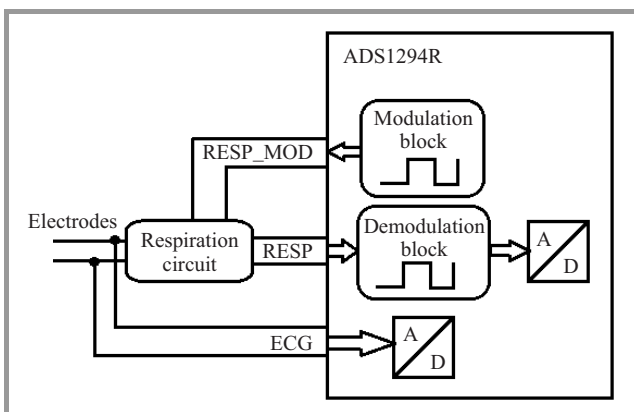

Fig. 5. A schematic diagram of thoracic electrical impedance measurement unit.

To generate alternating current, an internal modulator is used. It generates a square wave of 32 kHz frequency. The

more detailed circuit presented in the Fig. 6 is used for electrical impedance of thorax measurements.

Wires named RESP_MOD_N and RESP_MOD_P are the outputs of internal modulator. Resistors R31 and R32 sets the modulator current to approximately 117 μ A, while capacitors C71 and C72 blocks any DC current from flowing into patients body from the modulator side. Capacitors C69 and C70 do the same job from the receiver side. Additional protection is achieved using C25 and C26. They will block any DC current flowing through the patient's body, if there will be problems with one of the previous capacitors (like short circuit). Finally, resistors R26, R28, R29 and R30 are shifting input signal level to the middle of the ADC range. Nets ECG_RA and ECG_LA are connected directly to the electrodes on the patient's chest, while RESP_P and RESP_N goes to one of the inputs of ADC. Moreover, ECG_RA and ECG_LA are also connected to another ADC input, so the same electrodes are used for measuring impedance signal and capturing ECG signal.

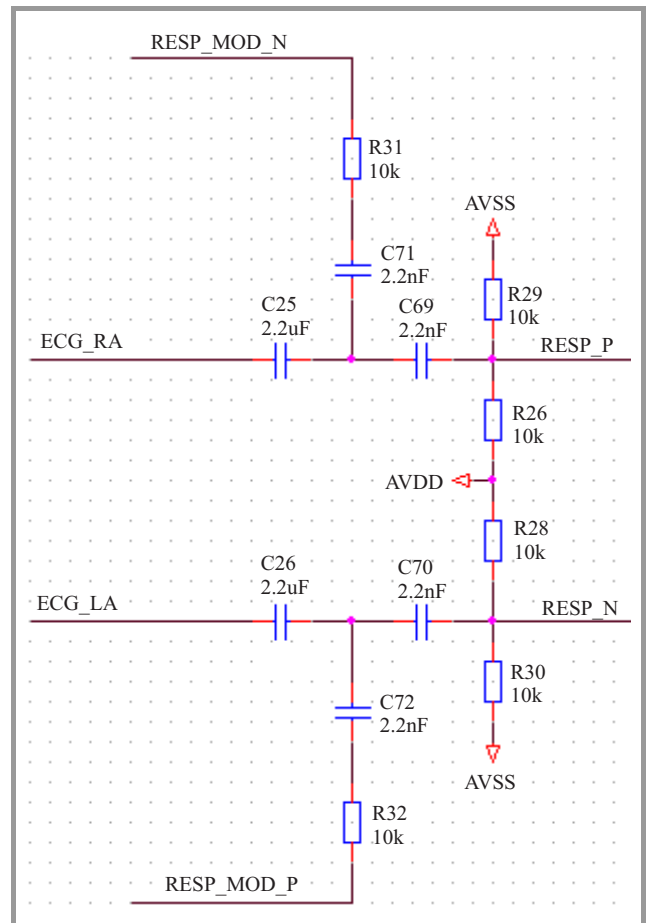

Fig. 6. Respiration measurement circuit.

Impedance signal has to be demodulated as information is hidden in its amplitude. The demodulation signal is simply the square wave signal at the same frequency as modulation signal, but with phase shift. The phase must be adjusted to account the phase delay in the signal path. For this project 135° phase shift is used.

Both ECG and thoracic impedance signals are sampled 250 times per second (250 Hz) with 24-bit resolution. Recorded data are transferred to microcontroller using SPI interface.

Larynx vibrations are measured using Freescale 3-axis, digital output, low power accelerometer MMA7455L. Data are sampled with 250 Hz frequency and 8-bit resolution. Selected sensitivity of the accelerometer is ± 2 g. SPI interface is utilized for transferring data to microcontroller.

Last part of the measurement section is ADMP401 microphone from Analog Devices. Analog output of the microphone is AC coupled, (DC part of the signal is removed by 1 μ F capacitor connected in series) and level shifted to fit with the ADC range. Then the 6th order analog filter is applied, with 500 HZ 3 dB cut-off frequency. Filter response has been presented in Fig. 7.

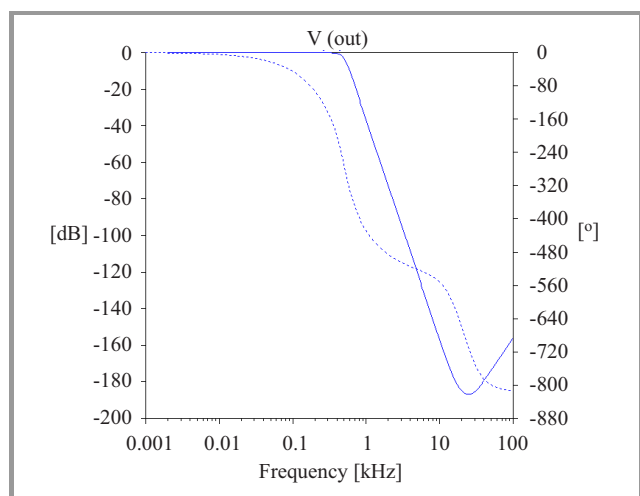

Fig. 7. Filter response.

The authors have used Sallen-Key filter topology and Butterworth response type. Finally, the signal is routed into 10-bit ADC, which is internal part of main microcontroller, and sampled with 1 kHz frequency.

Both accelerometer and microphone with additional analog circuits are placed on separate PCB. Those sensor are located close to the patient’s larynx during the examination (see Fig. 3).

2.3. Software Description

Microcontroller firmware has been prepared using MPLAB IDE environment. Its main goal is to collect the data from all the sensors and storing them on the Flash memory card. As mentioned before, it’s also possible to transmit recorded data in real-time to a PC computer or a mobile device using Bluetooth interface. After the power is on, the device goes into the idle mode and waits for the signal to start the examination. In order to start or complete the whole procedure, a patient needs only to press the single switch.

In this study, all of the analysis of recorded data has been performed on the external computer in Matlab.

3. Results

Proposed diagnostic prototype device has contains two, 4-layers printed circuit boards and the plastic enclosure made using 3D printing technology (Fig. 8). The devel-

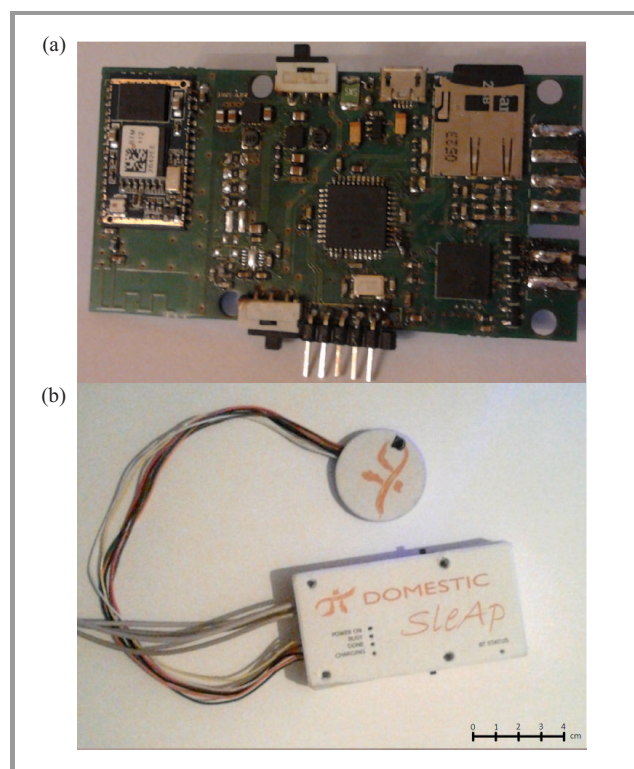

Fig. 8. The developed SleAp device: (a) PCB exposed and (b) assembled in enclosure.

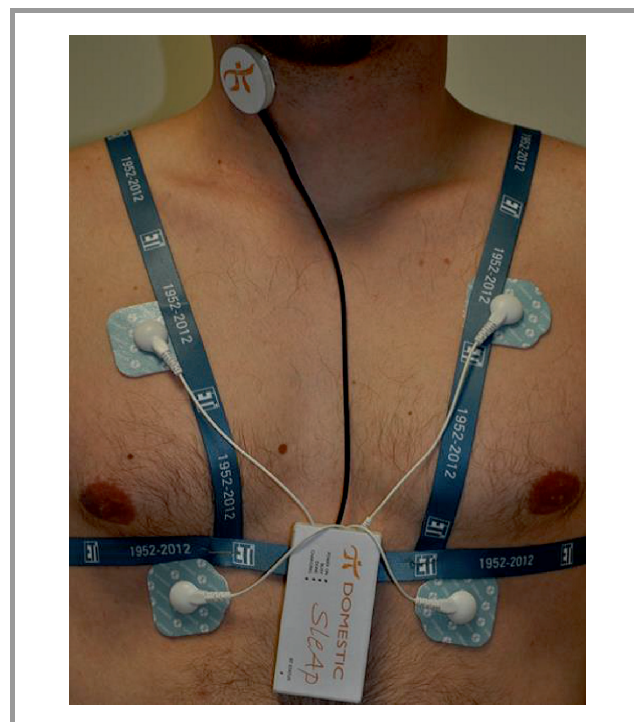

Fig. 9. The device attached to patient’s chest.

oped device was designed as small as possible in order to minimize disturbance during a nocturnal examinations. The device and the sensor were attached to the examined person body using a belts parachute-like system (Fig. 9).

In order to check the quality of the design, several tests were made. First the output voltage oscillation of DC-DC converters during full load was checked. Results are presented in Table 1 and oscillograms are presented in Fig. 10. Offset was applied only for better visibility of the measurements.

Table 1
Output voltage oscillation of DC-DC converters

Output voltage [V]	Oscillations [mV]	Oscillations [%]
3.3	3.8	0.12
2.5	0.5	0.02

Total current consumption was evaluated measuring voltage drop along the 1 Ω resistor. The results of experiments showed an average current consumption approximately 40 mA ±5 mA. Taking into account that the battery capacity is 1000 mAh, the device should work during 25 hours without the battery charging.

One of the most device important features is the wireless communication. Therefore, the range of Bluetooth interface was also tested. The BTM112 module is labeled as Class 2 device, so its theoretical range is about 10 m. Performed tests showed that the real range is about 9–10 m, and it drops down to 3 m in the presence of obstacles between the receiver and the transmitter (e.g. wall).

Finally the signals from patient’s chest were recorded. An example of recorded biosignals is shown in Fig. 11. The very important characteristic of the results is a lack of interferences and very high quality of signals. The amplitudes of registered signals are presented in Table 2.

Finally, the performance evaluation of lead-off detection function was investigated. First the offset in the signal was tested, made by the current source/sink from the lead-off circuit.

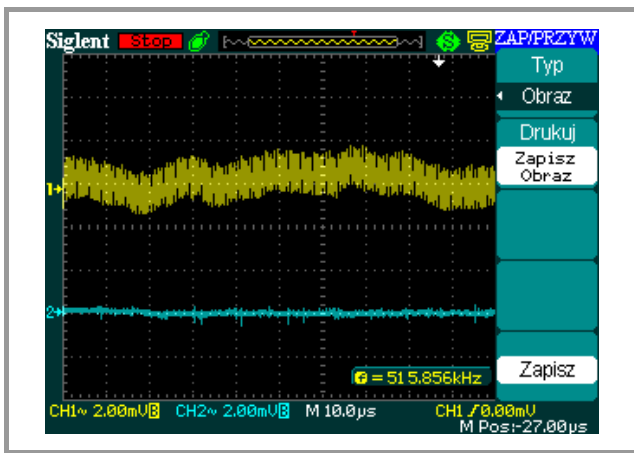

Fig. 10. Oscillations of output voltages for digital 3.3 V (upper signal) and for analog 2.5 V (lower part).

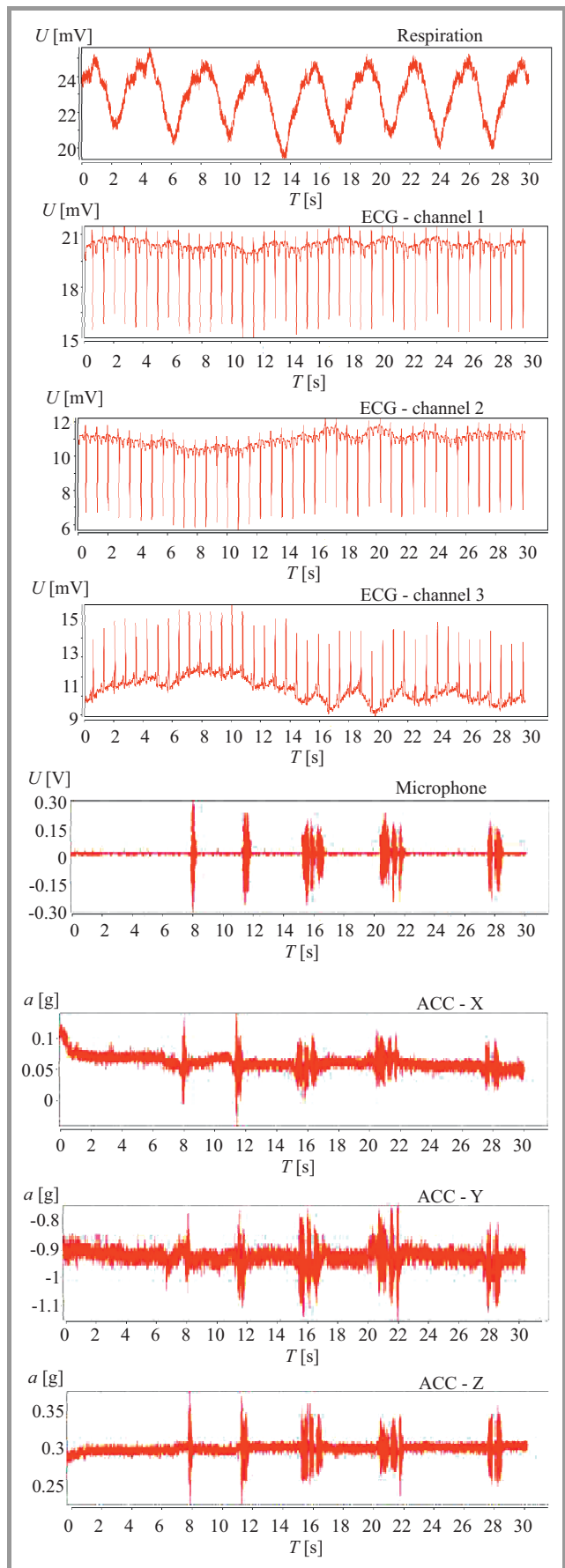

Fig. 11. An example of recorded biosignals (ACC stands for accelerometric signal).

Table 2
Output voltage oscillation of DC-DC converters

Signal type	Amplitude
Thoracic impedance	4 mV
ECG	66 mV
Snoring sound	0.77 V
Larynx vibrations	0.78 g (7.644 m/s ²)

The ECG signal was captured with lead-off detection turned on and off, and visualized using the common graph (Fig. 12). Measured offset between the signals is approximately 6 mV. When one of the electrodes was

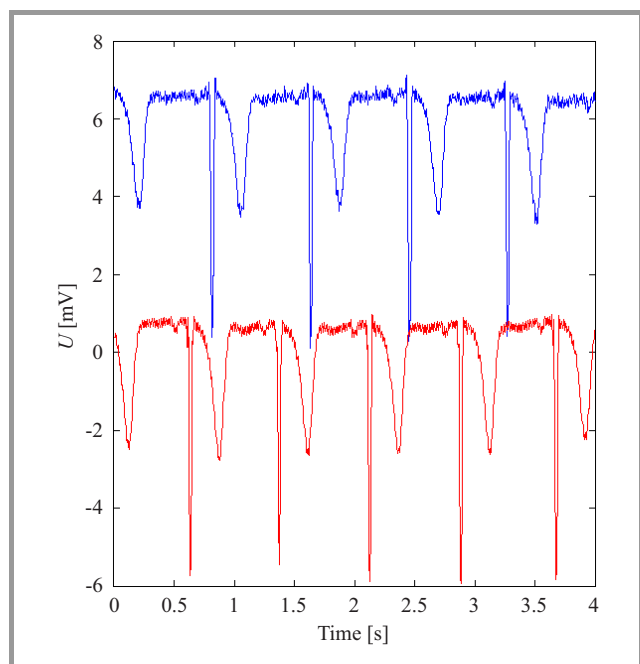

Fig. 12. Lead-off detection offset: lower signal – normal operation, upper signal – lead off detection turned on.

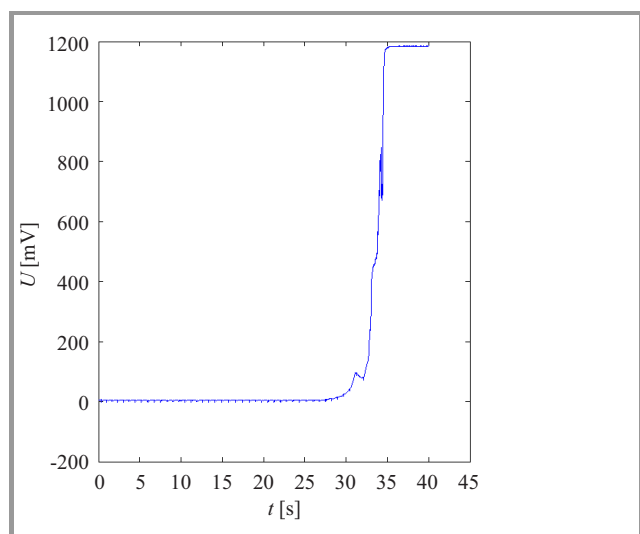

Fig. 13. Disconnecting one of the electrodes.

slowly disconnecting the output voltage started to increase slowly (Fig. 13). When the electrode was completely disconnected from the patient chest, the ADC converter was saturated. Additionally, suitable information was sent to the microcontroller.

4. Discussion

Multiple studies on the mutual dependence between the heart rate and breathing activities, confirmed the relationship between the respiratory and cardiovascular systems. The mechanism linking the two systems is related to Respiratory Sinus Arrhythmia (RSA). It is a physiological, natural variability observed in the heart rate during the respiratory cycle. As one breathe in, the heart rate increases, and during exhalation it decreases. Sinus arrhythmia detection in an electrocardiogram (e.g. using spectral analysis of ECG signal [14]) allows estimation of the respiration function. Every disorder in a normal respiration rhythm like pauses in breathing caused by obstructive sleep apnea, have also impact on the cardiovascular system. It is observable in ECG. Detailed ECG signal analysis in both time and frequency domain allows for the accurate detection and classification of sleep apnea events [8].

Respiration process has also great influence on the conditions of ECG measurement. During the breathing effort the movement of electrodes is observed, analyzing their mutual spatial locations and location in reference to the heart. This effect generates some changes in ECG signals, e.g., the modulation of amplitudes of QRS complexes. Such changes could be extracted from ECG signals and used to estimate the respiration function [15]. Unfortunately, such approach is exposed to errors, since information on respiration activity achieved by monitoring R wave amplitude is obtained non-uniformly in time.

Changes in body position during sleep also affect the ECG Derived Respiration (EDR) signal. The authors used this property proposing additional method for estimation of the respiration function. The method uses thoracic impedance measurement [16]. Variability of impedance is the result of the changes in the shape and chest volume during the study. Those changes are associated with the process of breathing. Additionally, the breathing activity influences the relative electrodes position. Movements of internal organs are also observed during lungs operation and the diaphragm. The changes in conductivity of tissues associated with alterations in the volume of gas in the lungs during inhalation and exhalation are also important [17].

It is possible, with certain reliability, to detect and classify obstructive sleep apnea events using the signals from the microphone and the accelerometer [18], [19]. Apnea events are very often associated with snoring episodes. However the snoring is not always connected with the sleep apnea. It is possible to detect the snoring episodes using analysis of snoring sounds and larynx vibrations. These analyses can also help to determine if snoring episodes are related to the apnea or not [20]. Additionally, data from the ac-

celerometer could be used to determine the patient's body position during sleep. This information could be used to make the analysis and classification results body position changes independent during the examination.

5. Conclusion

The experiments showed that the developed diagnostic device fulfills assumptions and requirements specified before the study. Performed tests proved that it is possible to record multichannel data with low noise and high quality. This was also achieved regardless of changes in body position. Four independent measurement channels available during all night recordings will help to prepare an automatic classification algorithm.

Additional information about the measurement obtained during sleep can be extremely useful. For example information about the quality of electrode connections give the possibility to assess the suitability of the data from the specific channel. Such additional information could be used to make a decision which ECG channel should be chosen for analysis, or omitted.

The aim of the future research will be to create a database with all-night measurements from larger group of people. This will further allow to evaluate the quality of SleAp device and analyzing algorithms development.

Acknowledgments

This work has been partially supported by European Regional Development Fund concerning the project: UDA-POIG.01.03.01-22-139/09-00 – “Home assistance for elders and disabled – DOMESTIC”, Innovative Economy 2007–2013, National Cohesion Strategy and by Statutory Funds of Electronics, Telecommunications and Informatics Faculty, Gdańsk University of Technology.

References

- [1] K. Šušmáková, “Human sleep and sleep EEG”, *Measur. Sci. Rev.*, vol. 4, no. 2, pp. 59–74, 2004.
- [2] P. Corkum, R. Tannock, H. Moldofsky, S. Hogg-Johnson, and T. Humphries, “Actigraphy and parental ratings of sleep in children with Attention-Deficit/Hyperactivity Disorder (ADHD)”, *Sleep*, vol. 24, no. 3, pp. 303–312, 2001.
- [3] The International Classification of Sleep Disorders, Revised, Diagnostic and Coding Manual, AASM, 2001.
- [4] S. Ram, H. Seirawan, S. Kumar, and G. Clark, “Prevalence and impact of sleep disorders and sleep habits in the United States”, *Sleep Breath*, vol. 14, no. 1, pp. 63–70, 2010.
- [5] B. Sivertsen *et al.*, “A comparison of actigraphy and polysomnography in older adults treated for chronic primary insomnia”, *Sleep*, vol. 29, no. 10, pp. 1353–1358, 2006.
- [6] A. Bar *et al.*, “Evaluation of a portable device based on peripheral arterial tone for unattended home sleep studies”, *Chest*, vol. 123, pp. 695–703, 2003.
- [7] A. Sadeh, “The role and validity of actigraphy in sleep medicine: an update”, *Sleep Med. Rev.*, vol. 15, pp. 259–267, 2011.

- [8] L. Almazaydeh, K. Elleithy, and M. Faezipour, “Obstructive sleep apnea detection using SVM-based classification of ECG signal features”, in *Proc. 34th IEEE Ann. Int. Conf. Engin. Med. Biol. Soc. IEEE EMBS 2012*, San Diego, CA, USA, 2012, pp. 4938–4941.
- [9] N. Collop *et al.*, “Obstructive sleep apnea devices for out-of-center (OOC) testing: technology evaluation”, *J. Clin. Sleep Med.*, vol. 15, pp. 531–548, 2011.
- [10] N. Netzer, A. H. Eliasson, C. Netzer, and D. A. Kristo, “Overnight pulse oximetry for sleep-disordered breathing in adults – A review”, *Chest*, vol. 120, pp. 625–633, 2001.
- [11] P. Przystup, A. Bujnowski, and J. Wtorek, “Projekt i implementacja wielokanałowego detektora bezdechu sennego (Project and implementation of multisensor sleep apnea detector)”, *Krajowe Sympozjum Telekomunikacji i Teleinformatyki (National Symposium of Telecommunication and Teleinformatics) KSTiT 2013*, Gdańsk, Poland, 2013 (in Polish).
- [12] Y. Sun and J. K. Fidler, “Design of Pi impedance matching networks”, in *Proc. IEEE Int. Symp. Circ. Sys. ISCAS 1994*, London, England, 1994, vol. 5, pp. 5–8.
- [13] Association for the Advancement of Medical Instrumentation AAMI, ANSI/AAMI EC13:2002 Cardiac monitors, heart rate meters, and alarms, 2002.
- [14] M. V. Pitzalis *et al.*, “Effect of respiratory rate on the relationships between RR interval and systolic blood pressure fluctuations: a frequency-dependent phenomenon”, *Cardiovascular Res.*, pp. 332–339, 1998.
- [15] P. Przystup, A. Polinski, and J. Wtorek, “The impact of electrodes configuration and measurement parameters on EDR signal”, in *Proc. XVIII Nat. Conf. of Biocybernetics and Biomedical Eng. KKBiB 2013*, Gdańsk, Poland, 2013 (in Polish).
- [16] J. Wtorek, *Techniki Elektroimpedancyjne w Medycynie (Electrical Impedance Technique in Medicine)*. Gdańsk: Publishing Office of Gdańsk University of Technology, 2003 (in Polish).
- [17] D. B. Geselowitz, “An application of electrocardiographic lead theory to impedance plethysmography”, *IEEE Trans. Biomed. Engin.*, vol. 18, pp. 38–41, 1971.
- [18] J. Sola-Soler, R. Jane, J. Fiz, and J. Morera, “Automatic classification of subjects with and without Sleep Apnea through snoring analysis”, in *Proc. 29th Ann. Int. Conf. IEEE Engin. Med. Biol. Soc. EMBC 2007*, Lyon, France, 2007, pp. 6093–6096.
- [19] C. Bucklin, M. Das, and S. Luo, “An inexpensive accelerometer-based sleep-apnea screening technique”, in *Proc. IEEE Nat. Aerosp. Electron. Conf. NAECON 2010*, Dayton, OH, USA, 2010, pp. 396–399.
- [20] P. Przystup, A. Bujnowski, J. Ruminski, and J. Wtorek, “A multi-sensor detector of a sleep apnea for using at home”, in *Proc. 6th Int. Conf. Human Sys. Interaction HSI'2013*, Sopot, Poland, 2013, pp. 513–517.



Piotr Przystup received his M.Sc. in Electronics from the Gdańsk University of Technology, Poland, in 2012. After that he started Ph.D. studies at the same University, at Biomedical Engineering Department. His current research focus is on sleep disorders and their connection with cardiovascular system diseases.

E-mail: piotr.przystup@gmail.com
 Department of Biomedical Engineering
 Gdańsk University of Technology
 Narutowicza st 11/12
 80-233 Gdańsk, Poland



Adam Bujnowski received his M.Sc., Eng. in Electronics in 1997 and Ph.D. in Electronics in 2007. He has spent 4 years working on few bilateral projects in cooperation with Vrije Universiteit of Brussels. He is also co-inventor and designer of several products developed in cooperation with industry. He is also author and co-

author of more than 80 publications and patents mainly in area of medical electronics and bioimpedance measurements. He is also a member of Polish Society of Medical Physics.

E-mail: bujnows@biomed.eti.pg.gda.pl
Department of Biomedical Engineering
Gdańsk University of Technology
Narutowicza st 11/12
80-233 Gdańsk, Poland



Jacek Rumiński received his M.Sc., Eng. in Electronics in 1995 and Ph.D. in Computer Science in 2002. He has spent about 2 years working on projects at different European institutions. Dr. Rumiński was selected as the expert to the European Standardization Body. He was a coordinator or an investigator in about 20 projects

receiving a number of awards, including for best papers, practical innovations (7 medals and awards) and also the Andronicos G. Kantsios Award. He is the author of more

than 140 papers, and several patent applications. He is currently the coordinator of the European RTD project entitled “eGLASSES – The interactive eyeglasses for mobile, perceptual computing”.

E-mail: jacek.ruminski@gmail.com
Department of Biomedical Engineering
Gdańsk University of Technology
Narutowicza st 11/12
80-233 Gdańsk, Poland



Jerzy Wtorek received the M.Sc., Ph.D., and D.Sc. degrees in Electronics, respectively in 1976, 1986 and 2004. He has a close scientific co-operation with ETRO Department of Vrije Universiteit Brussels where he has spent more than 2 years. He was a coordinator of 4 bilateral projects, and coordinated or worked as a main researcher

in more than 15 projects granted by KBN, MNiSW, NCBiR or NCN. Currently, he is a coordinator of project “Home assistance for elders and disabled – DOMESTIC”, financed in program Innovative Economy 2007–2013, National Cohesion Strategy. He published more than 200 conference and journal papers. He is co-author of 10 patents. Dr. J. Wtorek is a chair of Biomedical Engineering Department, Faculty of Electronics, Telecommunication and Informatics.

E-mail: jaolel@biomed.eti.pg.gda.pl
Department of Biomedical Engineering
Gdańsk University of Technology
Narutowicza st 11/12
80-233 Gdańsk, Poland