

# Variable-Weight Optical Code Division Multiple Access System using Different Detection Schemes

Saleh Seyedzadeh<sup>1</sup>, Majid Moghaddasi<sup>2</sup>, and Siti B. A. Anas<sup>2</sup>

<sup>1</sup> *Integrated Lightwave Research Group, Department of Electrical Engineering, University of Malaysia, Kuala Lumpur, Malaysia*

<sup>2</sup> *Wireless and Photonics Research Center of Excellence, Department of Computer and Communication Systems Engineering, University Putra Malaysia, UPM Serdang, Malaysia*

**Abstract**—In this paper a Variable Weight OCDMA (VW-OCDMA) system using KS code with Direct Decoding (DD), Complementary Subtraction (CS) and AND subtraction detections is proposed. System performance is analyzed using mathematical approximation and software simulation. In mathematical analysis, the effects of Phase-Induced Intensity Noise, shot noise and thermal noise are taken into account. Bit Error Rate of different users is plotted as a function of received optical power per chip with varying the bit rates and number of active users. It has been shown that for different bit rates and number of users, system using DD has better performance than the system applying CS and AND detection. Using DD scheme, the number of active users are 100 while this value is 27 and 25 in case of using CS and AND detection, respectively, when the received optical power per chip is  $-10$  dBm.

**Keywords**—AND detection, direct detection, QoS differentiation, spectral amplitude coding, variable-weight OCDMA.

## 1. Introduction

Recently, Optical Code Division Multiple Access (OCDMA) system has been considered for fiber optic communication as it provides asynchronous access, privacy, secure transmissions and service differentiation capability in metro network where applications such as video streaming and voice over IP require different amount of bandwidth portion [1]. In OCDMA system each user has a unique signature code, which distinguishes one user from the others. OCDMA systems have also received attention in optical sensor networks [2], [3] and free space optical communication [4].

Among the advantages of OCDMA systems, the ability to support application with various data rates and Quality of Service (QoS) requirements made it an attractive solution for metro networks as it deals with heterogeneous traffic [5]. Physical layer QoS was achievable using OCDMA by several means such as varying weight [6]–[8], length [9], [10] or both weight and length [11]. QoS differentiation with fixed weight and varying the number of existing users in matrix construction was also represented [12], [13]. Spectral Amplitude Coding (SAC) system has been considered as a candidate to provide QoS by varying the code weights for different users [14]. This is due to the fact that SAC does not require a complicated protocol or control.

Wavelength components of optical pulses are encoded at the spectral encoder by obstructing or transmitting specific wavelength components in accordance of a signature code. In receiver side a sort of filters are deployed to extract the desired signal for each user. SAC was first introduced by Zaccarin and Kavehrad [15], which eliminates the Multiple Access Interference by applying the right detection techniques. Experimental demonstration of QoS differentiation using SAC-OCDMA for three different services have been recently reported [16].

Three SAC detection techniques had been developed to decode the users' data, which are Direct Decoding (DD) [17], Complementary Subtraction (CS) detection [15] and AND subtraction detection [18].

VW-SAC system is proposed in this paper and comparison of such system using three different detection techniques is presented. VW-SAC supports service differentiation by varying the wavelength components where users with higher priority are assigned higher weights in order to have lower Bit Error Rate (BER).

First VW-OCDMA system is described in detail and VW-code construction is demonstrated. Then AND subtraction, CS and DD techniques are explained in terms of their architecture and mathematical representation. Numerical analysis is proposed to calculate approximate Signal-to-Noise Ratio (SNR) and BER of users of different weights. Finally, results are presented to evaluate the performance of the proposed system based on number of active users, received optical power and bit rate.

## 2. System Description

The architecture of a VW-SAC OCDMA system for  $k$  number of users with code weight of  $w$  is depicted in Fig. 1. For simplification purpose, only a pair of transmitter and receiver is shown.

At the transmitter side, power from a broadband source (BBS) spectrum is split among  $k$  users. A series of fiber Bragg gratings (FBGs) filter different wavelengths of  $\lambda_1, \dots, \lambda_w$  from the spectrum to form the different signature code with weight of  $w$ .

A Mach-Zehnder modulator (MZM) is used to modulate the users' binary data, which formed as Non-Return-to-Zero

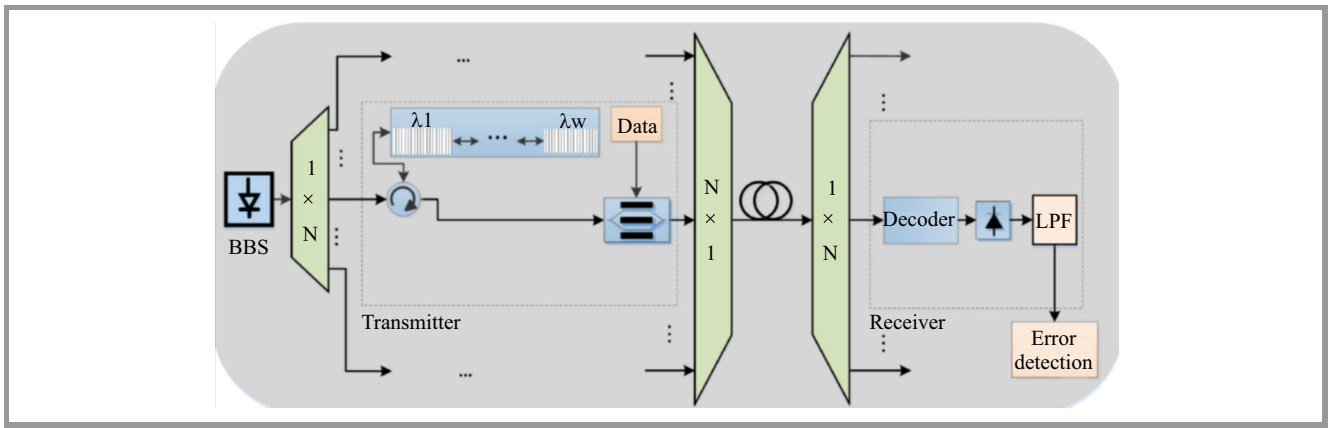

Fig. 1. Architecture of a VW-SAC OCDMA system.

(NRZ) signal to the optical carrier. Modulated signals from all users are then combined using a power combiner, and transmitted over the single mode fiber (SMF) based on ITU G652.

At the receiver part, one of the detection techniques developed for SAC-OCDMA may be applied to extract the desired data for each user. FBGs were used to filter the signals for all detection techniques. Each technique will be discussed in detail subsequently.

Among different codes developed for service differentiation in SAC-OCDMA systems are Integer Lattice OOC (IL-OOC) [6], Variable Weight Random Diagonal (VW-RD) [19] and Variable Weight code using Khazani-Syed (VW-KS) code [5]. In this analysis, VW-KS is used due to its ability to maintain a tolerable code length compared to others.

Table 1

Comparison of different variable weight codes properties

Code	No. of code weights	No. of users	Code length	$R_{\max}$
IL-OOC	4 {5, 4, 3, 1}	49	28	7
VW-RD	4 {6, 5, 4, 3}	50	74	5
VW-KS	4 {8, 6, 4, 2}	50	168	1

Table 1 presents the advantages and disadvantages of VW-KS against its counterparts in terms of code design. In terms of codes performance, the evaluation in terms of mathematical analysis will be presented and elaborated in Fig. 6 of Section 5, subsequently. In this example all code families support 50 users with four different weights. IL-OOC and VW-RD has shorter code length as compared to VW-KS code, however  $R_{\max}$  can reach up to 7 and 5, respectively, which might lead to poor Multiple Access Interference (MAI) cancellation. Although VW-KS has longer code length than IL-OOC and VW-RD, yet it guarantees the maximum cross-correlation of 1 between different users. Three weights of 6, 4 and 2 are used to support QoS in VW-OCDMA system which can be referred to voice, data and video signals, respectively.

### 3. SAC OCDMA Detection Techniques

The detection techniques AND, CS and DD are described in detail in this section. These three techniques will then be mathematically analyzed and the results are compared.

#### 3.1. AND Subtraction Technique

AND subtraction uses balanced detection to eliminate the effect of MAI. In this technique, two decoders are required in a single receiver, which are the upper and lower decoders. The upper decoder detects the desired code,  $x(\lambda)$  while the lower decoder detects binary logical AND of desired and interfering code,  $x(\lambda) \cap y(\lambda)$ , with  $y(\lambda)$  being the interferer signal of other codes having overlapping chip with desired user.

#### 3.2. Complementary Subtraction Detection

Most conventional SAC systems deploy CS using balanced detection as well as AND. In this technique, the upper decoder has the same structure as the encoder at the transmitter side  $x(\lambda)$ , while the lower decoder is the complement of the upper decoder  $\bar{x}(\lambda)$ . The decoded signals are then detected by a balanced receiver, which performs MAI cancellation.

#### 3.3. Direct Decoding Technique

DD is another subtraction technique, developed for SAC systems, where it only deploys one decoder unlike AND detection, which reduces the number of filters and receiver complexity.

DD only detects the non-overlapping code of the desired signal, which can be represented by  $x(\lambda) - x(\lambda) \cap y(\lambda)$ .

## 4. VW-Code Construction

VW-KS code will be explained as it is adopted in this research. This code was developed based on the single

weight KS code [20]. Firstly, a brief description of KS code and its construction is presented, then variable weight implementation are described in detail.

**4.1. Khazani-Syed Code**

KS code is based on matrix construction, where the two sub-codes  $A = [110]$  and  $B = [011]$  are used to construct the basic matrix. The structure of this code is causing that the cross-correlation  $R$  between each pair of different users' codes is zero or one, which results in reduction of MAI effect.

The size of basic matrix  $C_B$  for KS code ( $K \times N$ ) is depending on the code weight  $W$  ( $W = 2, 4, 6, \dots$ ), where  $K$  and  $N$  are the number of users and code length respectively. Construction of basic matrix for KS code is summarized as following steps [21]:

1. Fill the first row with sub-code  $A$  until number of chips equal to  $W$ .
2. Starting from second row, diagonally fill the matrix with sub-code  $B$  until last existing column.
3. Fill the empty spaces with zeros.
4. Repeat steps 1 to 3 starting from the second user until all code sequences get their weight.

The combination of every three columns needs to be [121] in order to be assured that the  $R_{xy}$  of one between each pair of codes will be obtained. An example of KS code construction with code weight of 4 is depicted in Fig. 2. It is seen that with code weight of 4, number of users and code length are 3 and 9 respectively.

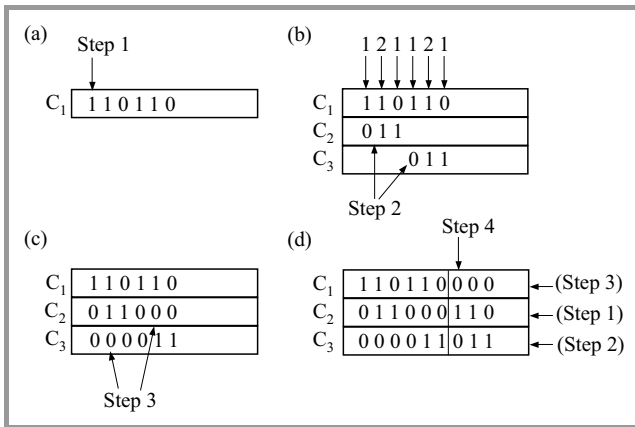

Fig. 2. Construction of KS [20].

The number of rows  $K_B$ , also known as basic number of users and number of columns  $N_B$  or basic code length are calculated by following equations:

$$K_B = \frac{W}{2} + 1 \quad (1)$$

and

$$N_B = 3 \sum_{i=1}^{\frac{W}{2}} i. \quad (2)$$

Using mapping technique, a large number of users  $K$  can be obtained from basic matrix  $C_B$ . This is carried out by repeating the basic matrix diagonally by  $M$  times, where  $M$  is the mapping sequence. This increases the maximum number of users by  $MK_B$ . The new large matrix resulted from applying mapping technique is

$$C(M) = \begin{bmatrix} C_{B,1} & 0 & 0 & 0 \\ 0 & C_{B,2} & 0 & 0 \\ 0 & 0 & C_{B,3} & 0 \\ 0 & 0 & 0 & C_{B,4} \end{bmatrix},$$

where  $C_{B,m}$  is  $C_B$  at the  $m$ -th mapping sequence,  $m = 1, 2, \dots, M$ .

Each 0 is a sequence of zeros with the same size of  $C_B$  and  $C(M)$  is the code at certain mapping number,  $M$ . Mapping of the basic matrix,  $C_B$  of weight two is depicted in Fig. 3, with  $M = 3$ .

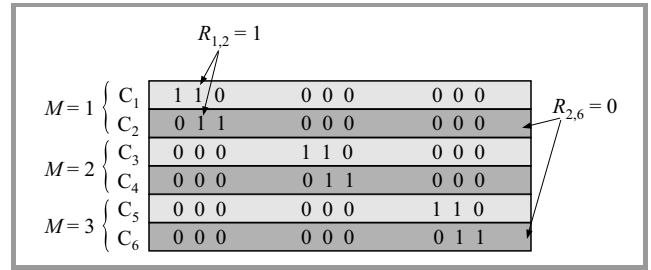

Fig. 3. Mapping process of KS code of weight 2 using  $M=3$  [20].

In the mapped matrix, as shown in the Fig. 3 the cross-correlation between each pair of users within the same mapping sequence is one; in the meantime,  $R_{xy}$  between two distinct codes in different mappings is zero. The maximum number of users,  $K_{max}$  and the corresponding code length,  $N_{max}$  obtained with mapping sequence,  $M$  can be derived as follow

$$K_{max}(M) = M \left( \frac{W}{2} \right) \quad (3)$$

and

$$N_{max}(M) = 3M \sum_{i=1}^{\frac{W}{2}} i \quad (4)$$

Mapping sequences,  $M$  needed for any specific number of users,  $K(M)$  is given by

$$M = \left\lceil \frac{K(M)}{\frac{W}{2}} \right\rceil. \quad (5)$$

**4.2. Construction of Variable Weight KS Code**

A mapping technique can be used to combine users of different service requirements. In this method, codes of different weights is ordered so that the  $R_{xy}$  of one is obtained.

This method is using the mapping techniques, which was used for extension of single weight KS code. However, in the VW-code each mapping sequence is devoted for a specific weight. Hence, the number of supportable users of a specific weight should first to be determined to generate sufficient codes. These generated codes of specific weight will later be mapped together to form a set of codes with variable weights. The general form of the constructed variable weight code,  $C_V$  is given by

$$C_V = \begin{bmatrix} C_{W_1, M_1} & 0 & 0 & 0 \\ 0 & C_{W_2, M_2} & 0 & 0 \\ 0 & 0 & \ddots & 0 \\ 0 & 0 & 0 & C_{W_J, M_J} \end{bmatrix}.$$

$C_{W_j, M_j}$  is the specific group of codes generated from the  $j$ -th weight and mapping, and  $J$  is the number of different weights in a system with  $j = 1, 2, \dots, J$ . Each 0 is a sequence of zeros with the same size of  $C_{W_j, M_j}$ .

## 5. Mathematical Analysis of VW-OCDMA System

In mathematical analysis, the effects of Phase-Induced Intensity Noise (PIIN), shot noise and thermal noise is considered. The noise variance of a photocurrent due to the detection of an ideally unpolarized thermal light, which is generated by spontaneous emission, can be written as [22]:

$$\langle I^2 \rangle = \langle I_{shot}^2 \rangle + \langle I_{PIIN}^2 \rangle + \langle I_{thermal}^2 \rangle, \quad (6)$$

where  $I_{shot}$  denotes the shot noise,  $I_{PIIN}$  represents the PIIN and  $I_{thermal}$  is the thermal noise. The coherence time of the thermal source,  $\tau_c$  is given by [23]:

$$\tau_c = \frac{\int_0^\infty G^2(v) dv}{\left[ \int_0^\infty G(v) dv \right]^2}, \quad (7)$$

where  $G(v)$  is the source power spectral density (PSD). The crosstalk from adjacent optical channels is ignored as chips spacing is assumed to be sufficiently wide [24]. This method gives an upper bound for the system performance [23], means the simulation and hardware results must be better than the numerical results calculated with this method.

This analysis is made with the following assumptions:

- each power spectral component has identical spectral width,
- each user receives equal power per chip at the receiver,
- each bit stream from each user is synchronized.

The PSD of the received signals can be written as [25]:

$$r(v) = \frac{P_{sr}}{\Delta v} \sum_{k=1}^K d_k \sum_{i=1}^N c_k(i) \Pi(i), \quad (8)$$

where  $P_{sr}$  is the effective power of source at receiver,  $\Delta v$  is the bandwidth of optical source,  $K$  and  $N$  are number of users and code length respectively,  $d_k$  is the information bit of  $k$ -th active user which is either "1" or "0" ( $d_k \in \{0, 1\}$ ),  $c_k(i)$  is the  $i$ -th element of the  $k$ -th KS code sequence and  $\Pi(i)$  is a function defined as:

$$\begin{aligned} \Pi(i) &= u \left[ v - v_0 - \frac{\Delta v}{2N} (-N + 2i - 2) \right] - \\ &\quad - u \left[ v - v_0 - \frac{\Delta v}{2N} (-N + 2i) \right] = \\ &= u \left[ \frac{\Delta v}{2N} \right], \end{aligned} \quad (9)$$

and  $u[v]$  is the unit step function expressed as:

$$u[v] = \begin{cases} 1, & v \geq 0 \\ 0, & v < 0 \end{cases}. \quad (10)$$

The following subsections explain and expand the analysis with respect to three different detection schemes, AND, CS and DD schemes.

### 5.1. AND Subtraction Detection

The VW-KS code properties for upper and lower arms of AND subtraction technique can be written as:

$$\sum_{i=1}^N c_k(i) c_l(i) = \begin{cases} W_k, & k = l \\ 1, & k \neq l, W_k = W_l \\ 0, & k \neq l, W_k \neq W_l \end{cases} \quad (11)$$

and

$$\sum_{i=1}^N c_k(i) (c_l(i) \cdot c_k(i)) = \begin{cases} W_k/2, & k = l \\ 1, & k \neq l, W_k = W_l \\ 0, & k \neq l, W_k \neq W_l \end{cases} \quad (12)$$

respectively, where  $W_k$  is the weight of  $k$ -th user. The number of users with same weight in a basic matrix,  $K_{B_w}$  is given by

$$K_{B_w} = \frac{W}{2} + 1. \quad (13)$$

Substituting Eqs. (11) and (12) in (8) and integrating them results into the total power incident at the upper and lower photodetectors, PIN 1 and PIN 2, respectively which can be written as:

$$\begin{aligned} \int_0^\infty G_1(v) dv &= \int_0^\infty \left[ \frac{P_{sr}}{\Delta v} \sum_{k=1}^K d_k \sum_{i=1}^N c_k(i) c_l(i) \times \right. \\ &\quad \left. \times \left\{ u \left[ \frac{\Delta v}{N} \right] \right\} \right] dv = \\ &= \frac{P_{sr}}{N} \left( W_k d_l + \sum_{\substack{k=1 \\ k \neq l}}^K d_k \right) \end{aligned} \quad (14)$$

and

$$\begin{aligned} \int_0^\infty G_2(v)dv &= \int_0^\infty \left[ \frac{P_{sr}}{\Delta v} \sum_{k=1}^K d_k \sum_{i=1}^N c_k(i) c_l(i) \times \right. \\ &\quad \left. \times c_k(i) \right] \times \left\{ u \left[ \frac{\Delta v}{N} \right] \right\}^2 dv = \\ &= \frac{P_{sr}}{N} \left( \frac{W_k}{2} d_l + \sum_{\substack{k=1 \\ k \neq l}}^K d_k \right). \end{aligned} \quad (15)$$

Let  $I_1$  and  $I_2$  be the photocurrent at PIN 1 and PIN 2, respectively. The photocurrent  $I$ , therefore, is given by:

$$I = I_1 - I_2 = \Re \left[ \int_0^\infty G_1(v) - \int_0^\infty G_2(v) \right] = \frac{\Re P_{sr} W_k}{2N_v} d_l, \quad (16)$$

where  $\Re = \eta e/h\nu$  is the photodiode responsivity. Here  $\eta$  is quantum efficiency,  $e$  is the electron charge,  $h$  is Planck's constant, and  $\nu$  is the central frequency of optical source's spectra.  $k$  in Eq. (16) represents the desired user, with respect to the occurrence of other users of different weights. Users of different weights is denoted by  $j = 1, 2, \dots, J$  where  $J$  is the total number of different weights in the system and  $N_v$  is the code length of variable weight users defined as [21]:

$$N_v = \sum_{j=1}^J N_{B_j} m_j, \quad (17)$$

where  $N_{B_j}$  and  $m_j$  is the number of user in basic matrix and the number of sequence with weight  $j$ .

The noise power of shot noise can be written as:

$$\begin{aligned} \langle I_{shot}^2 \rangle &= 2eB(I_1 + I_2) = \\ &= 2eB\Re \left( \int_0^\infty G_1(v) + \int_0^\infty G_2(v) \right) = \\ &= \frac{5eB\Re P_{sr} W_k}{N_v}, \end{aligned} \quad (18)$$

where  $B$  is half of the bit rate, which denotes the noise-equivalent electrical bandwidth of the receiver.

In order to calculate the variance of PIIN, the mean squared power of both PIN 1 and PIN 2 is first obtained by integrating  $G_1^2(v)$  and  $G_2^2(v)$ , such as [23]:

$$\begin{aligned} \int_0^\infty G_1^2(v)dv &= \int_0^\infty \left[ \frac{P_{sr}}{\Delta v} \sum_{k=1}^K d_k \sum_{i=1}^N c_k(i) c_l(i) \times \right. \\ &\quad \left. \times \left\{ u \left[ \frac{\Delta v}{N} \right] \right\}^2 \right] dv = \\ &= \frac{P_{sr}^2}{\Delta v N} \sum_{i=1}^N \left\{ c_l(i) \left[ \sum_{k=1}^K d_k c_k(i) \right] \times \right. \\ &\quad \left. \times \left[ \sum_{m=1}^K d_m c_m(i) \right] \right\} \end{aligned} \quad (19)$$

and

$$\begin{aligned} \int_0^\infty G_2^2(v)dv &= \int_0^\infty \left[ \frac{P_{sr}}{\Delta v} \sum_{k=1}^K d_k \sum_{i=1}^N c_k(i) c_l(i) \times \right. \\ &\quad \left. \times \left\{ u \left[ \frac{\Delta v}{N} \right] \right\}^2 \right] dv = \\ &= \frac{P_{sr}^2}{\Delta v N} \sum_{i=1}^N \left\{ c_l(i) \cdot c_k(i) \left[ \sum_{k=1}^K d_k c_k(i) \right] \times \right. \\ &\quad \left. \times \left[ \sum_{m=1}^K d_m c_m(i) \right] \right\}. \end{aligned} \quad (20)$$

In VW-KS code when all users are transmitting bit 1, the code sequence  $c_k$  can be approximated as:

$$\sum_{k=1}^K c_k \approx \frac{1}{N_v} \sum_{j=1}^J K_j W_j. \quad (21)$$

Using approximation in Eq. (21), the variance of PIIN can be written as:

$$\begin{aligned} \langle I_{PIIN}^2 \rangle &= B\Re \left( \int_0^\infty G_1^2(v) + \int_0^\infty G_2^2(v) \right) \cong \\ &\cong \frac{5B\Re P_{sr}^2 W_k}{2\Delta v N_v^2} \sum_{j=1}^J K_j W_j. \end{aligned} \quad (22)$$

The thermal noise is given as:

$$\langle I_{thermal}^2 \rangle = \frac{4K_b T_n B}{R_L}, \quad (23)$$

where  $K_b$  is Boltzmann's constant,  $T_n$  is received noise temperature and  $R_L$  represents the receiver load resistor.

Noting that the probability of sending bit 1 at any time for each user is  $\frac{1}{2}$ , the SNR of the VW-KS system deploying AND technique for users with weight  $k$  can be expressed as:

$$\begin{aligned} SNR_k &= \frac{(I_1 - I_2)^2}{\langle I^2 \rangle} = \\ &= \frac{\frac{\Re^2 P_{sr}^2 W_k^2}{4N_v^2}}{\frac{5eB\Re P_{sr} W_k}{N_v} + \frac{5B\Re P_{sr}^2 W_k}{4\Delta v N_v^2} \sum_{j=1}^J K_j W_j + \frac{4K_b T_n B}{R_L}}. \end{aligned} \quad (24)$$

Therefore, using Gaussian approximation, the BER of users with weight  $k$  for a multiple weight system is given by

$$P_{e_k} = \frac{1}{2} \operatorname{erfc} \left( \sqrt{\frac{SNR}{8}} \right). \quad (25)$$

## 5.2. Complementary Subtraction Detection

The correlation properties of the VW-KS code based on CS detection scheme users can be written as:

$$\sum_{i=1}^N c_k(i) c_l(i) = \begin{cases} W_k, & k = l \\ 1, & k \neq l, W_k = W_l \\ 0, & k \neq l, W_k \neq W_l \end{cases} \quad (26)$$

and

$$\sum_{i=1}^N c_k(i)\bar{c}_l(i) = \begin{cases} 0, & k = l \\ W_k - 1, & k \neq l, W_k = W_l \\ W_l, & k \neq l, W_k \neq W_l \end{cases} \quad (27)$$

In order to achieve proper cancelation of MAI, the complement cross-correlation  $\sum_{i=1}^N c_k(i)\bar{c}_l(i)$  is needed to be multiplied by  $1/W_k - 1$ . This is because weight of the complement signal (27) is  $1/W_k - 1$  times of the actual signal (26) when  $c_k$  is different with  $c_l$ .

Therefore, the subtraction can be written as:

$$\sum_{i=1}^N c_k(i)c_l(i) - \frac{1}{W_k - 1} \sum_{i=1}^N c_k(i)\bar{c}_l(i) = \begin{cases} W_k, & k = l \\ 0, & k \neq l, W_k = W_l \\ 0, & k \neq l, W_k \neq W_l \end{cases} \quad (28)$$

Equation (28) shows that a strong autocorrelation of the intended user's code weight  $W_k$  is obtained. The MAI is also eliminated as the weight zero is attained when the code sequences is unmatched.

The total power incident at the upper photodetector PIN 1 is calculated in (14). PIN 2 can be derived by substituting Eq. (27) in Eq. (8) as

$$\int_0^\infty G_2(v)dv = \int_0^\infty \left[ \frac{1}{W_k - 1} \frac{P_{sr}}{\Delta v} \sum_{k=1}^K d_k \sum_{i=1}^N c_k(i) \times \right. \\ \left. \times (c_l(i) \cdot c_k(i)) \left\{ u \left[ \frac{\Delta v}{N} \right] \right\} \right] dv = \frac{P_{sr}}{N} \left( \sum_{k \neq l}^K d_k \right). \quad (29)$$

Let  $I_1$  and  $I_2$  be the photocurrent at PIN 1 and PIN 2, respectively. Therefore, the photocurrent  $I$  is given by:

$$I = I_1 - I_2 = \Re \left[ \int_0^\infty G_1(v) - \int_0^\infty G_2(v) \right] = \frac{\Re P_{sr} W_k}{N_v} d_l. \quad (30)$$

The variance of shot noise in the photocurrent can be calculated as:

$$\langle I_{shot}^2 \rangle = 2eB(I_1 + I_2) = 2eB\Re \left( \int_0^\infty G_1(v) + \int_0^\infty G_2(v) \right) = \frac{4eB\Re P_{sr} W_k}{N_v}. \quad (31)$$

The mean squared power of PIN 1 is obtained in Eq. (19) and the mean squared power of PIN 2 is calculated by integrating  $G_2^2(v)$ :

$$\int_0^\infty G_2^2(v)dv = \int_0^\infty \left[ \frac{1}{W_k - 1} \frac{P_{sr}}{\Delta v} \sum_{k=1}^K d_k \sum_{i=1}^N c_k(i)\bar{c}_l(i) \times \right. \\ \left. \times \left\{ u \left[ \frac{\Delta v}{N} \right] \right\} \right]^2 dv = \frac{P_{sr}^2}{(W_k - 1)^2 \Delta v N} \sum_{i=1}^N \left\{ \bar{c}_l(i) \left[ \sum_{k=1}^K d_k c_k(i) \right] \times \right. \\ \left. \times \left[ \sum_{m=1}^K d_m c_m(i) \right] \right\}. \quad (32)$$

Using approximation Eq. (21), power of PIIN can be written as:

$$\langle I_{PIIN}^2 \rangle = B\Re \left( \int_0^\infty G_1^2(v) + \int_0^\infty G_2^2(v) \right) \cong \frac{B\Re P_{sr}^2}{\Delta v N_v^2} \sum_{j=1}^J K_j W_j \left( \frac{3}{2} W_k + \frac{W_k}{2(W_k - 1)} + \right. \\ \left. + \frac{\sum_{j=1}^J K_j W_j - (\frac{W_k}{2} + 1)}{(W_k - 1)^2} \right). \quad (33)$$

Noting that the probability of sending bit 1 at any time for each user is  $\frac{1}{2}$ , SNR of system using CS can be written as:

$$SNR_k = \frac{(I_1 - I_2)^2}{\langle I^2 \rangle} = \frac{\frac{\Re^2 P_{sr}^2 W_k^2}{N_v^2}}{\frac{4eB\Re P_{sr} W_k}{N_v} + \frac{B\Re P_{sr}^2}{2\Delta v N_v^2} \sum_{j=1}^J K_j W_j \left( \frac{3}{2} W_k + \frac{W_k}{2(W_k - 1)} \right) + \frac{4K_j T_n B}{R_L}} \quad (34)$$

BER of users can be calculated by substituting  $SNR_k$  in Eq. (34) into Eq. (25).

### 5.3. Direct Decoding

DD scheme only detects the non-overlapping spectra using a single receiver, thus only half of the weight assigned for a particular user is detected ( $\frac{W}{2}$ ). It is assumed that  $c_k(i)$  denotes the  $i$ -th element of the  $k$ -th KS code sequence, therefore the code properties for the KS code using this technique can be written as:

$$\sum_{i=1}^N c_k(i)c_l(i) = \begin{cases} W_k/2, & k = l \\ 0, & k \neq l \end{cases} \quad (35)$$

Using the same mathematical analysis as in Subsection 5.1 the PSD at the input of the photodetector  $G_{dd}(v)$  can be expressed as:

$$G_{dd}(v) = \frac{P_{sr}}{\Delta v} \sum_{k=1}^K d_k \sum_{i=1}^N c_k(i)c_l(i) \times \left\{ u \left[ \frac{\Delta v}{N} \right] \right\}. \quad (36)$$

Therefore, the photocurrent of the desired user's signal is

$$I_{dd} = \Re \int_0^\infty G_{dd}(v)dv = \frac{\Re P_{sr} W_k}{2N_v} d_l. \quad (37)$$

Since only the non-overlapping chip is filtered for DD technique, PIIN is negligible. The total noise here is considered to be only the sum of shot noise and thermal noise such as:

$$\langle I^2 \rangle = 2eBI_{dd} + \frac{4K_b T_n B}{R_L} = \frac{eB\Re P_{sr} W_k}{N_v} + \frac{4K_b T_n B}{R_L}. \quad (38)$$

Noting that the probability of sending bit 1 at any time for each user is  $\frac{1}{2}$ , the SNR of the VW-KS system deploying DD technique for users with weight  $k$  can be expressed as

$$SNR_k = \frac{(I_{dd})^2}{\langle I^2 \rangle} = \frac{\frac{\Re^2 P_{sr}^2 W_k^2}{4N_v^2}}{\frac{eB\Re P_{sr} W_k}{N_v} + \frac{4K_b T_n B}{R_L}}. \quad (39)$$

BER of users can be derived using Eq. (25).

## 6. Results and Discussion

The parameters used in mathematical analysis are listed in Table 2, as published by other researchers [18], [23].

Table 2  
Typical parameters used in the analysis

Symbol	Parameter	Value
$\eta$	Photodetector quantum efficiency	0.6
$\Delta\nu$	Linewidth of broadband source	3.75 THz
$P_{sr}$	Received optical power	-10 dBm
$B$	Electrical bandwidth	622 MHz
$\lambda_0$	Operating wavelength	1550 nm
$T_n$	Receiver noise temperature	300 K
$R_l$	Receiver load resistor	1030 $\Omega$
$e$	Electron charge	$1.6 \cdot 10^{-19}$ C
$h$	Planck's constant	$6.66 \cdot 10^{-34}$ Js
$K_b$	Boltzmann's constant	$1.38 \cdot 10^{-23}$ J/K

In all analyses, the number of active users with different weights are almost the same, i.e. each service (voice, data and video) has the same portion of total users.

Figure 4 illustrates the probability of error for users with different weights versus number of active users using IL-OOC, VW-RD and VW-KS, respectively, where CS is applied as detection technique. The SNR equation for multi-wavelength IL-OOC and VW-RD are extracted from [26], [27] and [19], [28], respectively. It is shown that even the code weights of VW-KS users (8, 6 and 2) are less than IL-OOC and VW-RD (22, 13 and 5), KS still outperform

them. This shows that although the code length of KS code families are longer than others, performance of the code is better due to smaller cross-correlation.

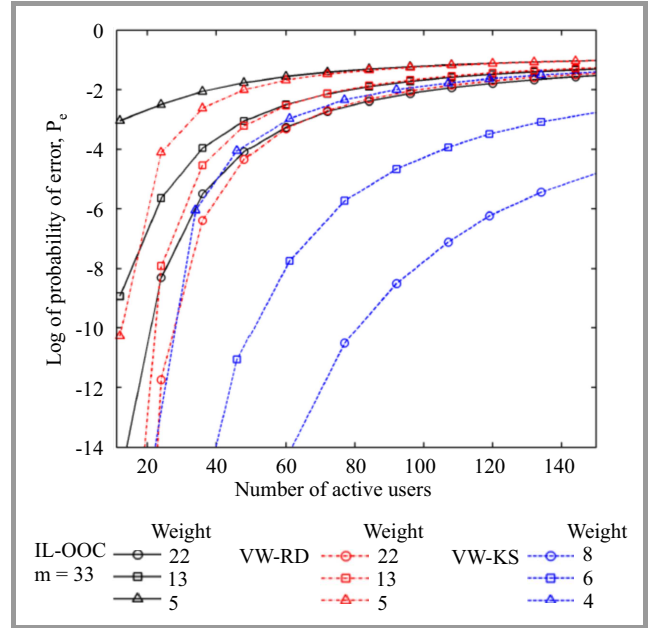

Fig. 4. Probability of error versus number of users for different code families.

(See color pictures online at [www.nit.eu/publications/journal-jtit](http://www.nit.eu/publications/journal-jtit))

Figure 5 shows the probability of errors for users with different weights versus number of active users, employing CS, AND and DD techniques. The total code length is increased by the increase of total number of users in the system, which reduces BER of all users. Moreover, performance of system deploying AND and CS is decreased

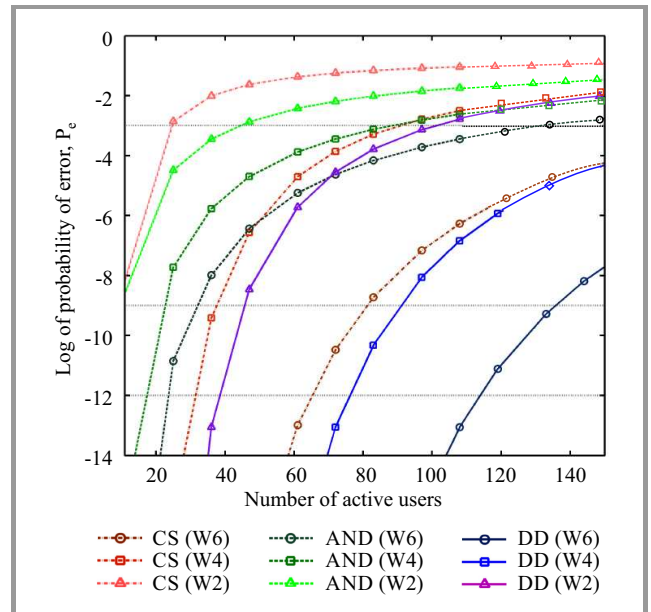

Fig. 5. Probability of error versus number of users.

further because of PIIN which have significant effect for lower weights. It is shown that performance of system deploying DD is much better than the system with AND and CS. The performance of users with different weights is much more differentiated employing DD technique. With reference to the BER of  $10^{-3}$ ,  $10^{-9}$  and  $10^{-12}$  for voice, data and video, respectively, the maximum number of active users that can be supported in a VW-OCDMA is 27, 25 and 100 deploying CS, AND and DD, respectively.

Figure 6 illustrates the probability of error as a function of probe optical received power per chip when number of active users is 11 and bit rate is 1.25 Gb/s. The number of users with weight 6, 4 and 2 is 4, 3 and 4, respectively and the total code length is 33. Figure 6 reveals that performance of systems with AND and CS detections is limited even with increase of received optical power. This is due to the PIIN noise, as performance of system with DD dramatically increases with gaining more power because DD detects only non-overlapping signals and avoid the PIIN.

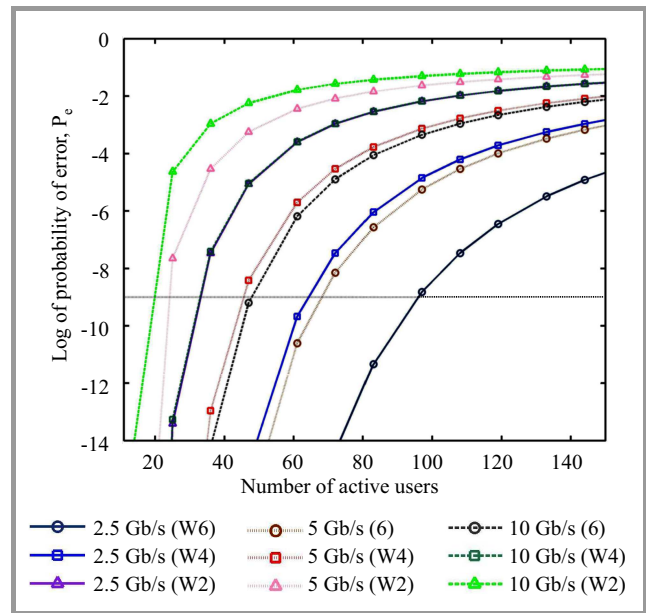

Fig. 7. Probability of error versus number of active users for different bit rates for DD technique.

the parameters used are the same as parameters used in numerical analysis. The chip spacing is chosen as 0.8 nm to avoid crosstalk between channels.

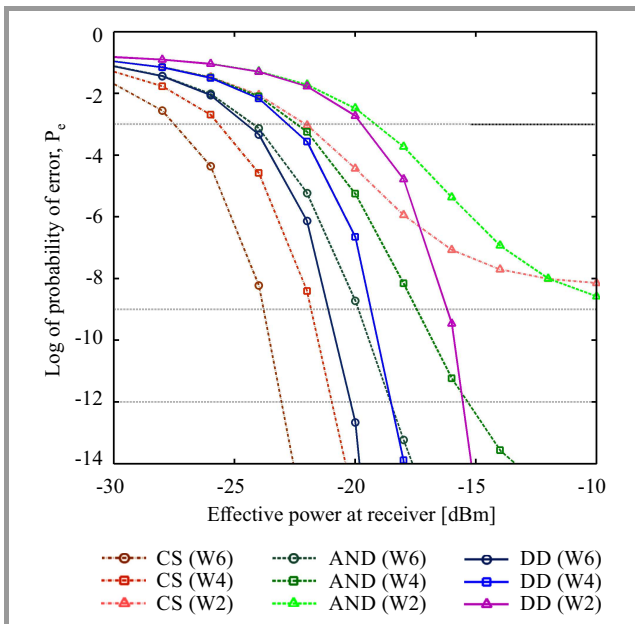

Fig. 6. Probability of error versus effective power per chip at receiver.

Figure 7 shows the plot of probability of error for the system using DD detection versus number of simultaneous users for bit rates of 2.5, 5 and 10 Gb/s, where  $P_{sr}$  is  $-10$  dBm. It is shown in Figs. 5 and 7 that the number of supportable users for VW-OCDMA system using DD technique is 46, 30, 24 and 20 for bit rates of 1.25, 2.5, 5 and 10 Gb/s, respectively, for BER of  $10^{-9}$  and all users with different weights.

Performance of a VW-OCDMA system with 11 active users is also analyzed using OptiSystem version 11 simulation software. The performance of system is investigated based on received optical power. In software simulation

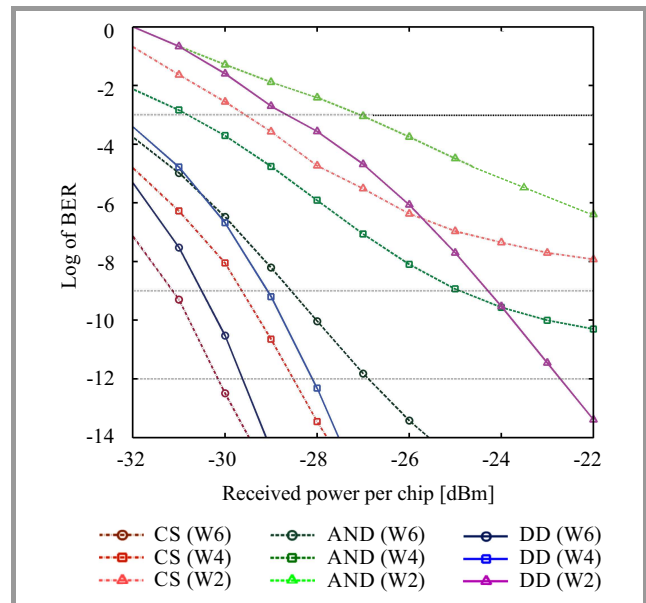

Fig. 8. BER versus effective power per chip at receiver.

Figure 8 shows the BER of users with different weights for the CS, AND and DD techniques. As mentioned, mathematical analysis approximates the upper bound for system performance. The simulation results proves this fact and also supports the numerical analysis. As depicted in Fig. 8, DD outperforms the other detections using balanced receiver in which PIIN significantly reduces the system performance.



## 7. Conclusion

In this paper performance of a VW-OCDMA system using AND, CD and DD techniques was numerically analyzed and compared to simulation result. Effects of different parameters including number of users, optical received power and bit rate was investigated. It has been shown that performance of system employing DD technique is much better than system with CS and AND subtraction. The obtained results showed that when received power per chip is  $-10$  dBm, system deploying DD can support up to 100 users while this amount is 25 and 27 for the system with CD and AND detections, respectively. The difference between number of supportable users using CS, AND and DD becomes further differentiated by the increase of received power. VW-OCDMA with DD technique with reduced complexity and number of filters offers a great potential in service differentiation in physical layer.

## Acknowledgment

The work described in this paper is funded by Research University Grant Scheme (RUGS) of Universiti Putra Malaysia. The authors would like to thank all those who have contributed towards the success of this project.

## References

- [1] H. Ghafouri-Shiraz and M. M. Karbassian, *Optical CDMA Networks: Principles, Analysis and Applications*. Wiley-IEEE Press, 2012.
- [2] A. Noura, S. Seyedzadeh, and S. Anas, "Simultaneous vibration and humidity measurement using a hybrid WDM/OCDMA sensor network", in *Proc. 4th IEEE Int. Conf. Photon. ICP 2013*, Melaka, Malaysia, 2013, pp. 163–165.
- [3] A. Taiwo, S. Seyedzadeh, S. Taiwo, R. Sahbudin, M. Yaacob, and M. Mokhtar, "Performance and comparison of fiber vibration sensing using SAC-OCDMA with direct decoding techniques", *Optik – Int. J. for Light and Electron Optics*, vol. 128, no. 17, pp. 4803–4806, 2014.
- [4] T. Ohtsuki, "Performance analysis of atmospheric optical PPM CDMA systems", *J. Lightw. Technol.*, vol. 21, no. 2, pp. 406–411, 2003.
- [5] S. Anas, T. Quinlan, and S. Walker, "Service differentiated drop code unit for metro ring optical networks", *IET Optoelec.*, vol. 4, no. 1, pp. 46–50, 2010.
- [6] I. Djordjevic, B. Vasic, and J. Rorison, "Multi-weight unipolar codes for multimedia spectral-amplitude-coding optical CDMA systems", *IEEE Commun. Lett.*, vol. 8, no. 4, pp. 259–261, 2004.
- [7] N. Nasaruddin and T. Tsujioka, "Design of strict variable-weight optical orthogonal codes for differentiated quality of service in optical CDMA networks", *Comp. Netw.*, vol. 52, no. 10, pp. 2077–2086, 2008.
- [8] S. Seyedzadeh, R. Sahbudin, A. Abas, and S. Anas, "Weight optimization of variable weight OCDMA for triple-play services", in *Proc. 4th IEEE Int. Conf. on Photon. ICP 2013*, Melaka, Malaysia, 2013, pp. 99–101, 2013.
- [9] S. Maric, O. Moreno, and C. Corrada, "Multimedia transmission in fiber-optic LANs using optical CDMA", *J. Lightw. Technol.*, vol. 14, no. 10, pp. 2149–2153, 1996.
- [10] W. Kwong, "Design of multilength optical orthogonal codes for optical CDMA multimedia networks", *IEEE Trans. Commun.*, vol. 50, no. 8, pp. 1258–1265, 2002.
- [11] W. Kwong and G.-C. Yang, "Multiple-length multiple-wavelength optical orthogonal codes for optical CDMA systems supporting multirate multimedia services", *IEEE J. Sel. Areas in Commun.*, vol. 22, no. 9, pp. 1640–1647, 2004.
- [12] M. H. Kakaee, S. Seyedzadeh, H. A. Fadhil, S. B. Ahmad Anas, and M. Mokhtar, "New dynamic technique for SAC-OCDMA system", in *Proc. 4th IEEE Int. Conf. Photon. ICP 2013*, Melaka, Malaysia, 2013, pp. 120–122.
- [13] M. H. Kakaee, S. Seyedzadeh, H. Adnan Fadhil, S. Barirah Ahmad Anas, and M. Mokhtar, "Development of multi-service (MS) for SAC-OCDMA systems", *Optics & Laser Technol.*, vol. 60, pp. 49–55, 2014.
- [14] P. R. Prucnal, *Optical Code Division Multiple Access: Fundamentals and Applications*. CRC Taylor & Francis, 2006.
- [15] D. Zaccarin and M. Kavehrad, "An optical CDMA system based on spectral encoding of LED", *IEEE Photon. Technol. Lett.*, vol. 5, no. 4, pp. 479–482, Apr. 1993.
- [16] S. Seyedzadeh, G. A. Mahdiraji, R. K. Z. Sahbudin, A. F. Abas, and S. B. A. Anas, "Experimental demonstration of variable weight SAC-OCDMA system for QoS differentiation", *Opt. Fiber Technol.*, vol. 20, no. 5, pp. 495–500, 2014.
- [17] M. K. Abdullah, F. N. Hasoon, S. Aljunid, and S. Shaari, "Performance of OCDMA systems with new spectral direct detection (SDD) technique using enhanced double weight (EDW) code", *Optics Commun.*, vol. 281, no. 18, pp. 4658–4662, 2008.
- [18] R. Sahbudin, S. Aljunid, M. Abdullah, M. B. A. Samad, M. Mahdi, and M. Ismail, "Comparative performance of hybrid SCM SAC-OCDMA system using complementary and AND subtraction detection techniques", *The Int. Arab J. of Inform. Technol.*, vol. 5, no. 1, pp. 61–65, 2006.
- [19] H. A. Fadhil, S. Aljunid, and R. Badlisha, "Triple-play services using random diagonal code for spectral amplitude coding OCDMA systems", *J. of Optical Commun.*, vol. 30, no. 3, pp. 155–159, 2009.
- [20] S. Ahmad Anas, M. Abdullah, M. Mokhtar, S. Aljunid, and S. Walker, "Optical domain service differentiation using spectral-amplitude-coding", *Opt. Fiber Technol.*, vol. 15, pp. 26–32, no. 1, 2009.
- [21] M. Abdullah, S. Aljunid, S. Anas, R. Sahbudin, and M. Mokhtar, "A new optical spectral amplitude coding sequence: Khazani-Syed (KS) code", in *Proc. 5th Int. Conf. Inform. & Commun. Technol. ICICT 2007*, Dhaka, Bangladesh, 2007, pp. 266–278.
- [22] Z. Wei, H. Shalaby, and H. Ghafouri-Shiraz, "Modified quadratic congruence codes for fiber Bragg-grating-based spectral-amplitude-coding optical CDMA systems", *J. Lightw. Technol.*, vol. 19, no. 9, pp. 1274–1281, 2001.
- [23] E. Smith, R. Blaikie, and D. Taylor, "Performance enhancement of spectral-amplitude-coding optical CDMA using pulse-position modulation", *IEEE Trans. Commun.*, vol. 46, no. 9, pp. 1176–1185, 1998.
- [24] L. Chao, "Effect of laser diode characteristics on the performance of an SCM-OFDM direct detection system", *IEE Proc. J. Optoelectron.*, vol. 140, no. 6, pp. 392–396, 1993.
- [25] C.-C. Yang, J.-F. Huang, and S.-P. Tseng, "Optical CDMA network codecs structured with M-sequence codes over waveguide-grating routers", *IEEE Photon. Technol. Lett.*, vol. 16, no. 2, pp. 641–643, 2004.
- [26] I. Djordjevic and B. Vasic, "Novel combinatorial constructions of optical orthogonal codes for incoherent optical CDMA systems", *J. Lightw. Technol.*, vol. 21, pp. 1869–1875, 2003.
- [27] I. Djordjevic, B. Vasic, and J. Rorison, "Design of multiweight unipolar codes for multimedia optical CDMA applications based on pairwise balanced designs", *J. Lightw. Technol.*, vol. 21, no. 9, pp. 1850–1856, 2003.
- [28] H. A. Fadhil, S. Aljunid, and R. Ahmad, "Performance of random diagonal code for OCDMA systems using new spectral direct detection technique", *Opt. Fiber Technol.*, vol. 15, no. 3, pp. 283–289, 2009.



**Saleh Seyedzadeh** received his B.Sc. degree in Software Engineering from SUT, Iran (2008) and M.Sc. degree in the area of optical communication system from University Putra Malaysia, Malaysia (2013). Currently he is a researcher at Department of Electrical Engineering, University of Malaya and member of Integrated Lightwave Research

Group (ILRG). His research interests include optical CDMA, quality of service in optical networks, optical hybrid modulation, and optical sensors.

E-mail: s.seyyedzadeh@gmail.com

Integrated Lightwave Research Group  
Department of Electrical Engineering  
University of Malaysia  
Jalan University  
50603 Kuala Lumpur, Malaysia



**Majid Moghaddasi** received the M.Sc. degree in Communication and Computer Engineering from National University of Malaysia in 2011. From 2012 he been a member of Wireless and Photonic Networks Research Center (WiPNET) in the Department of Computer and Communication Systems En-

gineering of Universiti Putra Malaysia (UPM) and worked as a research assistant. His research interests include optical CDMA, free-space optics, optical networks, and computer networks.

E-mail: majidmoghaddasi@ieee.org

Wireless and Photonics Research Center of Excellence  
Department of Computer  
and Communication Systems Engineering  
University Putra Malaysia  
UPM Serdang  
Malaysia

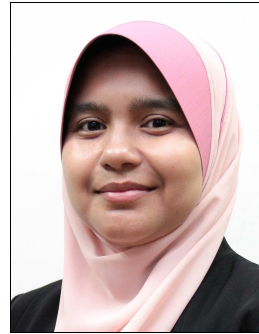

**Siti Barirah Ahmad Anas** obtained her Ph.D. in 2009 from University of Essex specializing in optical CDMA. She received an M.Sc. from Universiti Putra Malaysia (2003) and a B.Eng. from University of Strathclyde (1999). She is currently an Associate Professor in the Faculty of Engineering, UPM. Her research interests include optical

communication and networks.

E-mail: barirah@upm.edu.my

Wireless and Photonics Research Center of Excellence  
Department of Computer  
and Communication Systems Engineering  
University Putra Malaysia  
UPM Serdang  
Malaysia