

MIMO Antenna Design and Optimization with Enhanced Bandwidth for Wireless Applications

Mekala Harinath Reddy¹ and D. Sheela²

¹ School of Engineering, University of Leicester, Leicester, United Kingdom

² Department of ECE, Tagore Engineering College, Chennai, India

<https://doi.org/10.26636/jtit.2020.145520>

Abstract—This paper demonstrates a compact MIMO (Multi Input Multi Output) fractal type antenna for ultra-wide band applications. The proposed antenna is manufactured on a low-cost substrate material and the design is analyzed for various iterations in terms of reflection coefficient, gain, and bandwidth. The 50 Ω transmission line feed is used for both fractal patches and a metamaterial structure is used as the ground plane. The proposed design achieved a wide-band frequency response between 5.8 and 15 GHz, with the reflection coefficient of less than -10 dB. Reduced mutual coupling, positive gain and stable radiation patterns were observed throughout the operating band as well. The bandwidth of 9.2 GHz is achieved with the use of a metamaterial structure on the ground plane. The ECC and diversity gain obtained prove the excellent diversity performance of the antenna. The design was simulated using HFSS software and was tested in a lab.

Keywords—HFSS, metamaterial, mutual coupling, permittivity, reflection coefficient

1. Introduction

A microstrip patch antenna is one of the most popular types of printed type aerials. It plays a significant role in today's world of wireless communication [1]. Due to its miniature size, low cost of manufacturing and light weight, such a type is preferred over other antennas in many applications [2]. Microstrip patch antennas offer numerous advantages and many other technologies have been invented for bandwidth enhancement and high gain [3].

A MIMO antenna is one of such technologies, where multiple antennas are used forming a system at the transmitter and the receiver, improving the quality of wireless communication by link multiplication [4]. MIMO is relied upon to explore high performance and low-cost antenna layouts, as well as to support multimedia services with high channel capacities and transmission speeds [5]. The main advantage of this type of antenna is that it is capable of sending and receiving data via multiple channels at the same time, without any need of additional radiation power and

additional spectrum bandwidth utilization [6]. For antenna designers, it is very challenging to design a MIMO antenna with multiple patch elements on the same substrate [7], i.e. to achieve proper spacing between the individual elements in order to avoid mutual coupling [8], and to ensure good isolation within the wide frequency band.

In this paper, a compact fractal MIMO antenna for UWB applications is designed with a metamaterial structure serving as the ground plane. Fractal geometry is used for miniaturization purposes and to increase the perimeter of the patch. The metamaterial structure helps in enhancing the bandwidth of the antenna and in boosting performance in terms of impedance matching, bandwidth, and peak gain. Because of the maximum miniaturization potential, the spaces between radiating components are very small, and coupling between them is calculated to achieve a good diversity performance attained due to the use of the metamaterial structure. The design is worked out and optimized with the use of HFSS software.

2. Antenna Geometry

The design is based on a typical FR4 substrate material. The design process incorporates four iterations to obtain the correct fractal structure (Fig. 1). The process begins with a monopole antenna using a hexagonal slot. In the course of the iterations, another hexagonal slot is loaded into the previous fractal iteration and so on. The design process is limited to four iterations due to fabrication-related issues.

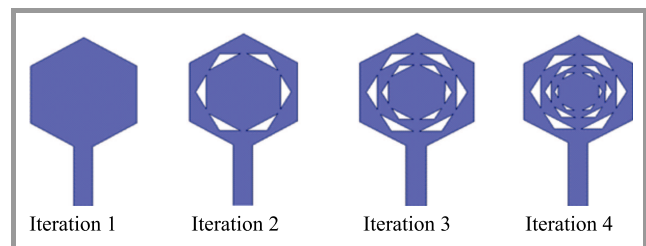

Fig. 1. Fractal iterations of the antenna design.

By using a circular monopole, the radius of the hexagonal patch is derived from:

$$R = \frac{F}{\left\{1 + \frac{2h}{\pi\epsilon_r F} \left[\ln \frac{\pi F}{2h} + 1.7726\right]\right\}^{\frac{1}{2}}}, \quad (1)$$

where:

$$F = \frac{8.791 \cdot 10^9}{f_r \sqrt{\epsilon_r}}. \quad (2)$$

The final MIMO antenna is shown in Fig. 2. The bottom layer of the antenna contains the metamaterial split ring resonator structure (Fig. 3), comprising two rectangular rings with a split on either side of the rings. This structure is developed by removing the inner middle part of the ground and inserting another rectangular ring inside the outer ring. Together, the inner ring and the outer ring form the split ring structure.

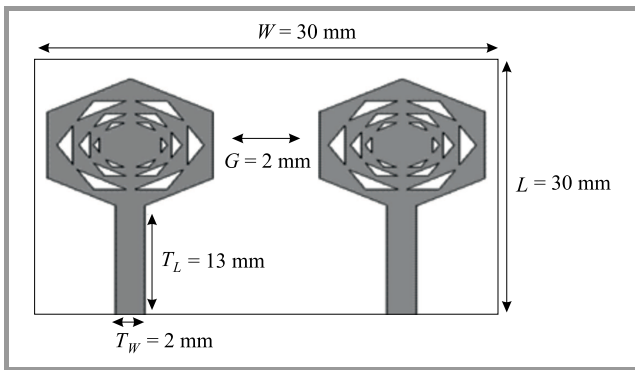

Fig. 2. Final MIMO antenna design.

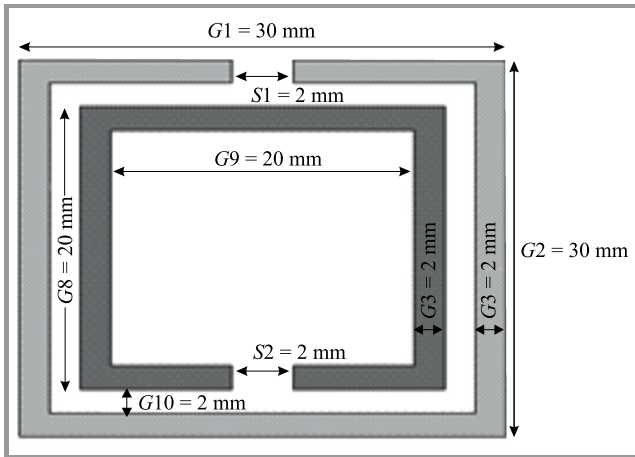

Fig. 3. Split ring resonator on the lower side of the substrate.

3. Results and Discussions

The comparison of the return loss parameter for all four fractal iterations is shown in Fig. 4. The minimum return loss value is achieved in the last iteration. Upon comparing the outcomes, it becomes obvious that as the iteration number increases, a good impedance matching is observed

between the feed line and the patch. Simulation results show that the operating band of 5.8–15 GHz is obtained.

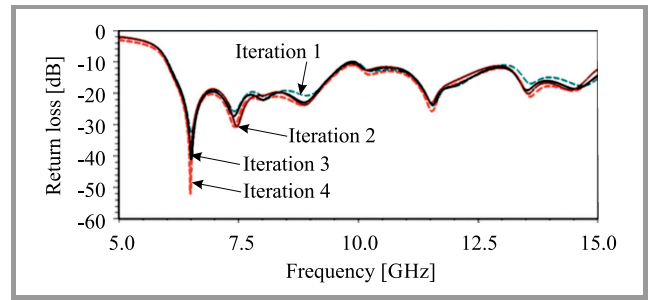

Fig. 4. Return loss comparison of each iteration. (For color pictures see the digital version of the paper).

Figure 5 shows the simulated gain of the proposed antenna for all four iterations. Positive gain is observed throughout the entire operating band. The highest gain of 6.2 dB is observed at 14 GHz. It is also noticed that there is not much difference in the gain as the iteration number increases.

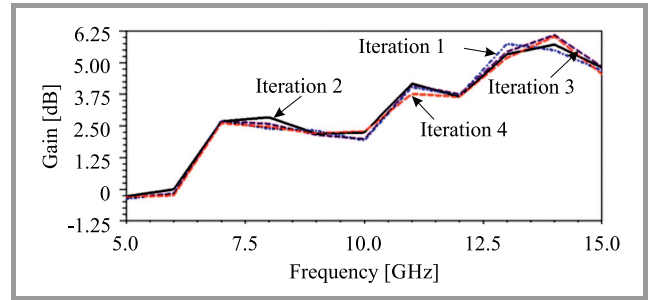

Fig. 5. Frequency vs. gain of the proposed antenna.

Figure 6 presents radiation patterns at E plane and H plane at 5, 8 and 12 GHz, respectively. It shows that the H plane pattern is omnidirectional and that the E plane pattern is bidirectional, therefore forming a stable pattern.

The fabricated prototype of the proposed antenna is shown in Fig. 7. It has the overall dimensions of 30×30×1.6 mm. The gap between two radiators is just 2 mm. A bigger gap between the radiators might lead to an increase in overall antenna dimensions. The antenna is designed in such a way that good isolation is ensured between the radiating elements, despite the fact that they are placed in close proximity to each other.

Figure 8 illustrates the measured performance of the MIMO antenna that is compared with the simulation data. Both the simulated and measured parameters are nearly the same and prove that the solution is suitable for UWB applications. Figure 9 shows the measured and simulated mutual coupling characteristics of the antenna. The measurement shows that the coupling between the two elements is below -25 dB. In addition, it was observed that the use of SRR structure reduces the coupling from -10 dB to -25 dB. In Fig. 10, the measured and the simulated peak gain is illustrated for different frequencies.

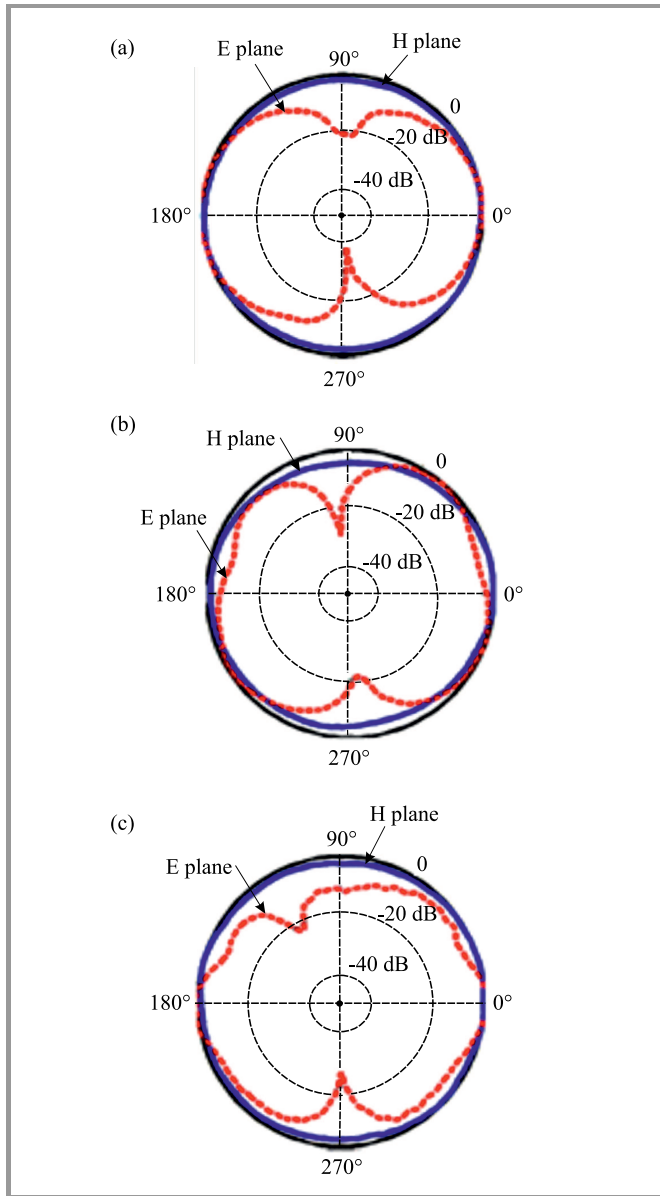

Fig. 6. Measured radiation patterns at: (a) 5 GHz, (b) 8 GHz, and (c) 12 GHz of (blue line: E plane and red (dashed) line: E plane).

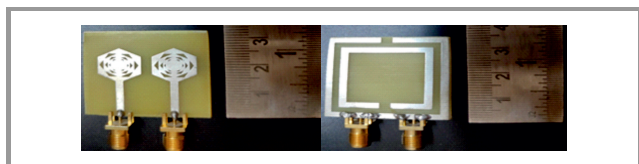

Fig. 7. Fabricated prototype of the antenna.

Figure 11 presents the distribution of surface current on the radiating elements and on the metamaterial structure at 3 frequencies: 5, 8 and 12 GHz. This pattern is obtained using the HFSS simulator. The magnitude of the antenna's surface current is displayed in different colors, and the magnitude levels with their corresponding colors are shown in the legend, next to each diagram. The blue color at the bot-

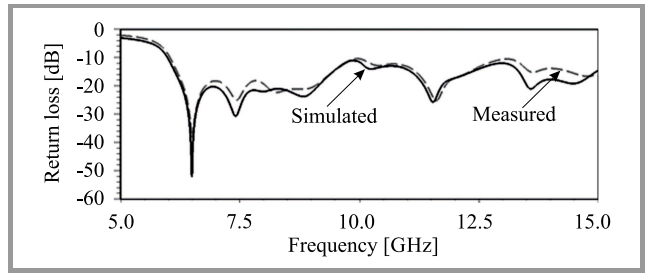

Fig. 8. Simulated vs. measured return loss of the proposed antenna.

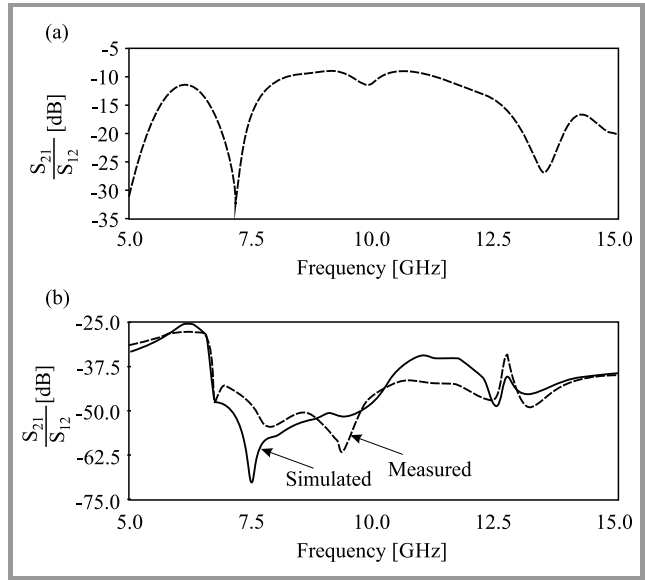

Fig. 9. Isolation characteristics between the radiating elements: (a) without SRR and (b) with SRR.

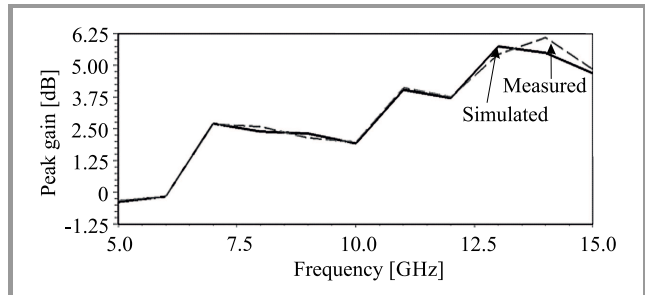

Fig. 10. Peak gain vs. frequency of antenna.

tom of the legend box correspond to the minimum surface current and the red color shows the maximum current. In Fig. 10a, the fractal portion is yellow in color at 5 GHz indicating high current distribution, whereas in Fig. 10c, the fractal portion is blue in color at 12 GHz, indicating relatively low surface current distribution. Therefore, current intensity is high at low frequencies, in comparison to high frequencies.

The capability (diversity performance) of a MIMO antenna may be validated using the ECC parameter. Based on S parameters, ECC may be calculated using [15]:

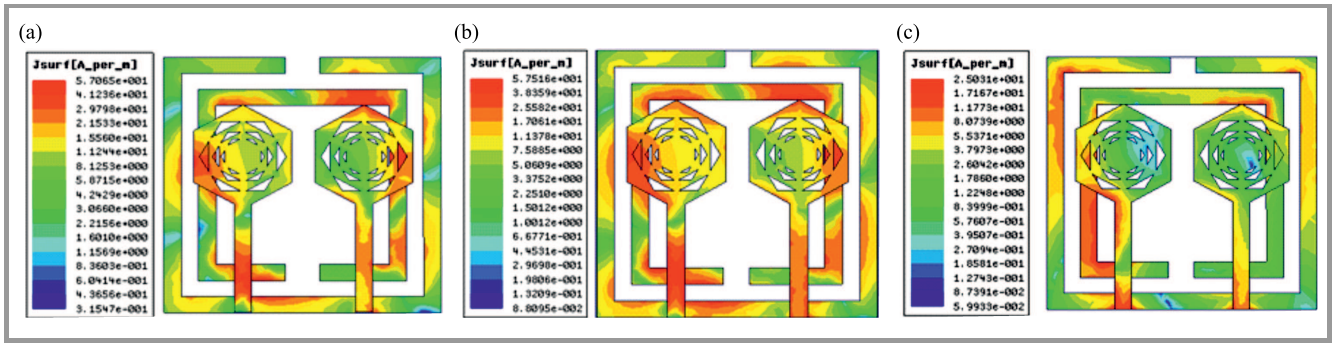

Fig. 11. Current distribution at: (a) 5 GHz, (b) 8 GHz, and (c) 12 GHz. (For color pictures see the digital version of the paper).

$$ECC = \frac{|S_{11}^* S_{12} + S_{21}^* S_{22}|^2}{(1 - |S_{11}|^2 - |S_{21}|^2)(1 - |S_{22}|^2 - |S_{12}|^2)}, \quad (3)$$

Ideally, the ECC value should be zero, but the typical limit is < 0.5 . For the desired antenna, the ECC is below 0.025 over the frequency range of 6 to 15 GHz, as shown in Fig. 12 and remains within the aforementioned limit.

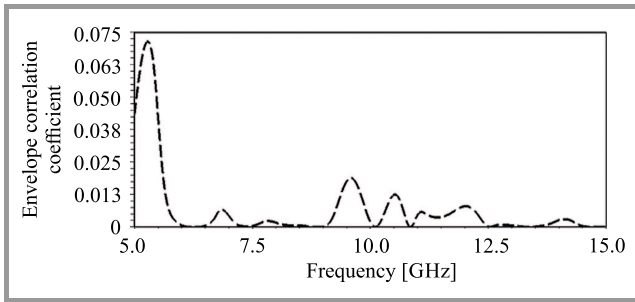

Fig. 12. ECC plot.

The effectiveness of diversity can be assured based on another important parameter, known as diversity gain (DG). DG is a function of ECC and may be calculated using [15]:

$$DG = 10 \cdot \sqrt{1 - |0.99 \cdot ECC|^2}. \quad (4)$$

DG of the desired antenna is illustrated in Fig. 13 and equals almost 10 dB.

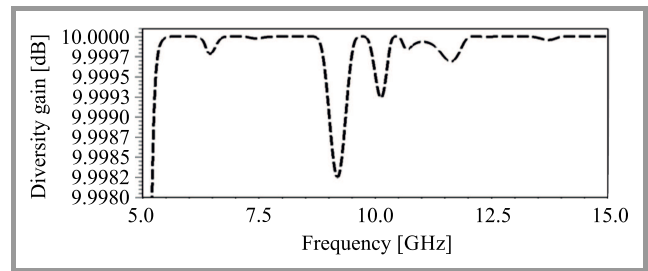

Fig. 13. Diversity gain.

The comparison of performance the proposed antenna with other designs known from literature is shown in Table 1. The proposed solution is compact compared to other designs and supports the maximum frequency range of 15 GHz. While the percentage bandwidth may be higher in a few other papers, the proposed design offers the best isolation of -25 dB with good ECC and diversity gain. The spacing between two radiating elements is just 3 mm. When compared with other available designs the coupling between the elements is reduced significantly, despite the fact that the elements are placed very close to each other.

Table 1
Comparison of performance of the designed antenna and of other solutions proposed in literature

Reference	Dimensions [mm]	Frequency band [GHz]	Bandwidth percentage	Isolation [dB]	ECC	DG [dB]
[9]	45×37	3.1–5	47	< -12	< 0.5	NA
[10]	50×30	2.5–14.5	141.17	< -17	< 0.04	> 7.4
[11]	40×80	4.5–8	56	< -20	< 0.02	> 9.94
[12]	35×68	3.1–10.65	109.89	< -16	< 0.04	NA
[13]	40×40	3.1–11	112	< -22	< 0.02	> 9.98
[14]	48×48	3–11	114	< -17	NA	NA
Proposed solution	30×30	5.8–15	90	< -25	< 0.025	> 9.9

4. Conclusion

A compact MIMO antenna is proposed and analyzed in this paper for four fractal design iterations. The obtained bandwidth is 9.2 GHz with a maximum gain of 6.2 dB at 14 GHz and with a reduced mutual coupling of -25 dB throughout the operational frequency. The antenna has a bidirectional pattern of radiation in the H plane and an omnidirectional pattern along the E plane. The stable radiation patterns, coupling characteristics and reflection coefficients show that the antenna may be used for ultra-wide band applications. Also, the obtained ECC and DG values prove good diversity performance. The impedance bandwidth of this MIMO antenna is suitable for WiMAX and WLAN applications as well.

References

- [1] A. Mehdipour, A. R. Sebak, and C. W. Trueman, "Novel ultrawideband slot-antenna with dual band-notched characteristics", in *IEEE Antenn. and Propag. Society Int. Symp.*, San Diego, CA, USA, 2008 (DOI: 10.1109/APS.2008.4620056).
- [2] M. A. Matin, "Stacked E-Shaped patch antenna for lower-band ultrawideband (UWB) applications", in *IET Int. Conf. on Wireless, Mobile and Multimedia Networks*, Beijing, China, 2008 (DOI: 10.1049/cp:20080132).
- [3] M. H. Reddy, R. Sheeba, and S. T. Niba, "Design of microstrip patch antenna for space environment with minimum return loss", *Res. J. of Pharmaceutical, Biological and Chemical Sci.*, vol. 8, no. 2, pp. 2678, 2017 [Online]. Available: [https://www.rjpbcs.com/pdf/2017_8\(2\)/\[300\].pdf](https://www.rjpbcs.com/pdf/2017_8(2)/[300].pdf)
- [4] M. H. Reddy, R. M. Joany, G. Manikandan, and A. S. A. Nisha, "Design of microstrip patch antenna with multiple slots for satellite communication", in *Int. Conf. on Commun. and Signal Proces.*, April 2017, Chennai, India, 2018 (DOI: 10.1109/ICCSP.2017.8286482).
- [5] M. Sugadev and E. Logashanmugam, "Quad band U-slot microstrip antenna for C, X and Ku band wireless applications", *Contemporary Engin. Sci.*, vol. 8, no. 13, pp. 737–745, 2015 (DOI: 10.12988/ces.2015.53115).
- [6] W. P. Siriwongpairat and K. J. R. Liu, *Ultra-Wideband Communications Systems: Multiband OFDM Approach*. Wiley-IEEE Press, 2007 (ISBN: 9780470074695).
- [7] Y. Rahayu, "Reconfigurable ultra wideband antenna design and development for wireless communication", Ph.D. Thesis (unpublished), Universiti Teknologi Malaysia, Malaysia, 2008.
- [8] Y. Zehforoosh, C. Ghobadi, and J. Nourinia, "Antenna design for ultra wideband application using a new multilayer structure", *PIERS Online*, vol. 2, no. 6, 2006 (DOI: 10.2529/PIERS060531145356).
- [9] T. S. P. See and Z. N. Chen, "An ultrawideband diversity antenna", *IEEE Trans. on Antenn. and Propag.*, vol. 57, no. 6, pp. 1597–1605, 2009 (DOI: 10.1109/TAP.2009.2019908).
- [10] A. Iqbal, O. A. Saraereh, A. W. Ahmad, and S. Bashir, "Mutual coupling reduction using F-shaped stubs in UWB-MIMO antenna", *IEEE Access*, vol. 6, pp. 2755–2759, 2017 (DOI: 10.1109/ACCESS.2017.2785232).
- [11] A. H. Jabire, H.-X. Zheng, A. Abdu, and Z. Song, "Characteristic mode analysis and design of wide band MIMO antenna consisting of metamaterial unit cell", *Electronics*, vol. 8, no. 1, 2019 (DOI: 10.3390/electronics8010068).
- [12] W. T. Li, Y. Q. Hei, H. Subbaraman, X. W. Shi, and R. T. Chen, "Novel printed filtenna with dual notches and good out-of-band characteristics for UWB-MIMO applications", *IEEE Microw. and Wirel. Compon. Lett.*, vol. 26, no. 10, pp. 765–767, 2016 (DOI: 10.1109/LMWC.2016.2601298).
- [13] W. A. E. Ali, A. A. Ibrahim, "A compact double-sided MIMO antenna with an improved isolation for UWB applications", *AEU – Int. J. of Electronics and Commun.*, vol. 82, pp. 7–13, 2017 (DOI: 10.1016/j.aeue.2017.07.031).
- [14] C.-X. Mao and Q.-X. Chu, "Compact coradiator UWB-MIMO antenna with dual polarization", *IEEE Trans. on Antenn. and Propag.*, vol. 62, no. 9, pp. 4474–4480, 2014 (DOI: 10.1109/TAP.2014.2333066).
- [15] M. H. Reddy, D. Sheela, V. K. Parbot, and A. Sharma, "A compact metamaterial inspired UWB-MIMO fractal antenna with reduced mutual coupling", *Microsystem Technologies*, pp. 1–13, 2020 (DOI: 10.1007/s00542-020-05024-z).



Mekala Harinath Reddy received his undergraduate degree in Electronics and Communication Engineering from Sathyabama University, Chennai, India in 2017. He received the Star of Excellence Award for the best graduate if Sathyabama University. His interests are in microwaves and antennas. He has published more than 8 papers in indexed

international journals and conferences. Currently, he is pursuing an M.Sc. in Information and Communications Engineering at the University of Leicester, UK.

 <https://orcid.org/0000-0003-0321-5421>

E-mail: harinath.m1995@gmail.com

School of Engineering
University of Leicester
Leicester
United Kingdom



D. Sheela received her Ph.D. degree in Information and Communication Engineering from Anna University in Chennai and is working as a Professor in the Department of Electronics and Communication Engineering, Tagore Engineering College, Chennai. She has 28 years of teaching, research and industry experience. She published several papers in reputed inter-

national journals and conferences. Her areas of interests are optical communication, networking, wireless communication and antennas.

 <https://orcid.org/0000-0002-0974-3922>

E-mail: dsheelatagorerandd@gmail.com

Department of ECE
Tagore Engineering College
Chennai
India