

Spectral Division of the Optical Fiber Passband Using Narrowband Controllable Filter on the Base of Semiconductor Waveguide Microresonator

Igor Goncharenko, Alexander Esman, Grigory Zykov, Vladimir Kuleshov, Marian Marciniak, and Vladimir Pilipovich

Abstract—We analyze the new principle of multichannel spectral division of optical fiber passband using controllable narrowband integrated optical filters composed of two-coupled ring microresonators made of different semiconductor materials. It is shown that appropriate selecting the semiconductor material and optimizing the design factors of selective optical element allows creating the simple and economical integrated optical filter with bandwidth 0.1 nm, frequency separation between adjacent optical carriers 0.2 nm and signal-to-noise ratio 50 dB. Utilizing such filters in optical fiber communication lines makes it possible to increase the number of transmitted in parallel optical carrier wavelengths up to 160 and even more, i.e., to provide the traffic transmission with the speed up to 1.6 Tbit/s in one direction and in single optical fiber.

Keywords—carrier injection, controllable optical filter, coupled waveguides, optical passband, resonance wavelength, resonator optical length, ring microresonator.

1. Introduction

The rapid growth of the needs of modern society in large data streams, and first of all the Internet, stimulates the research oriented on increasing the carrying capacity of optical communication channels. Wavelength division multiplexing (WDM) and dense wavelength division multiplexing (DWDM) technologies are increasingly effectively used for construction of high-speed main lines and optical communication networks. The permanent extension of carrying capacity of optical fiber communication lines on that way arises due to application of the latest achievements of theoretical and experimental research from the one hand, and new achievements of optical technology time division multiplexing (TDM) from the other hand [1–4].

The parallel transmission of N data streams on corresponding carrier optical wavelength $\lambda_1 \dots \lambda_N$ allows extending the carrying capacity of optical communication lines based on WDM/DWDM technologies by adding progressively the new optical channels as the network develops. The nar-

rowband optical filter with the passband controllable with the high speed is the key element of such devices and is used for spectral multiplexing/demultiplexing of optical channels.

In present paper we consider the multichannel spectral division of optical fiber passband on the base of microresonators made from different semiconductor materials. The physical essence of the method is in shifting the microresonator resonance wavelength because of the changing its optical length by varying the free charge carriers density influencing on the material refractive indices [5].

2. Structure of the Filter and Method of Calculation of its Parameters

The structural diagram of the proposed narrowband controllable integrated optical filter is shown in Fig. 1. The filter constitutes two sequentially optically coupled ring waveguide microresonators with band radius of tens of microns, which disposed on the distance 200 nm from each other and from straight input and output optical waveguides. The interaction length and gap width between the waveguides define their optical coupling coefficient. The narrow optical frequency bands corresponding to the resonance frequencies couple from the input waveguide to the microresonator [6, 7]. By changing the resonance conditions (for instance, by changing the resonator optical length, i.e., its geometrical length or waveguide effective index) one can vary the frequency band coupled into resonator. The effective index of the waveguide made from semiconductor materials can be changed by optical or electrical injection of the free carriers [5, 8]. For electrical injection the n-doped regions are created outside the ring microresonators while the p-doped regions are disposed inside the rings. When the electrical voltage is supplied on such diode structure the electrons and holes penetrate into the waveguide material and change its effective index and thereby the resonance frequency.

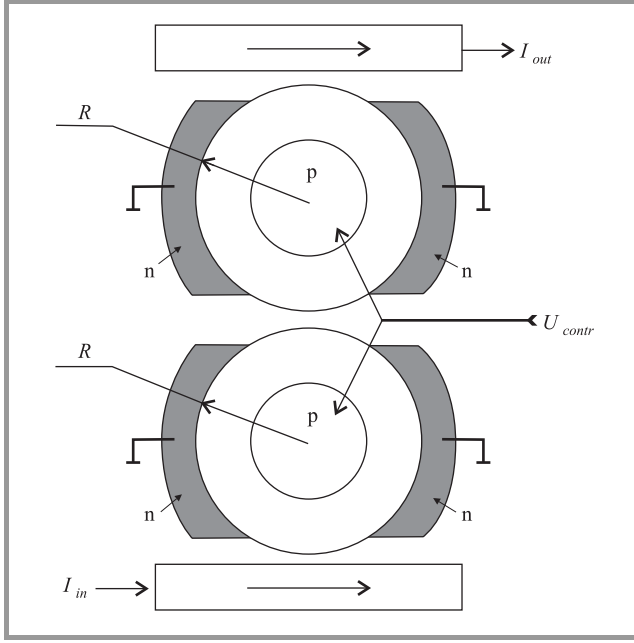

Fig. 1. The structural diagram of controllable integrated optical filter on the base of two optically coupled waveguide ring microresonators.

We implement the numerical simulations for analysis of the parameters of controllable integrated optical filter on the base of ring waveguide microresonators. In order to obtain the electromagnetic fields distribution on the filter input and output corresponding to different time points, resonance and transfer characteristics of the resonator we solve the wave equation written for Borgnis' electrical function [9]. That allows us to content only the considering E_z component of transverse magnetic-wave for the structure composed of two straight waveguides and optically sequentially coupled ring microresonators and in this way to apply the d'Alembert's equation in Cartesian coordinates [10]

$$\frac{\partial^2 E_z}{\partial x^2} + \frac{\partial^2 E_z}{\partial y^2} - \frac{n_S^2}{c^2} \frac{\partial^2 E_z}{\partial t^2} = 0 \quad (1)$$

for straight waveguides and in cylindrical coordinates:

$$\frac{1}{\rho} \frac{\partial}{\partial \rho} \left(\rho \frac{\partial E_z}{\partial \rho} \right) + \frac{1}{\rho^2} \frac{\partial^2 E_z}{\partial \varphi^2} - \frac{n_R^2}{c^2} \frac{\partial^2 E_z}{\partial t^2} = 0 \quad (2)$$

for ring microresonators, where n_S and n_R are the effective refractive indices of the input and output waveguides and ring microresonators, respectively.

The input and boundary conditions complete the equations (1, 2). For solving the wave equations (1, 2) with three variables we use the explicit numerical model of the "cross" type [11]. In accordance with this model the spatial and time derivatives of the second order in wave equation

in Cartesian and cylindrical coordinates Eqs. (1, 2) are substituted for

$$\frac{\partial^2 E_z}{\partial x^2} \approx \frac{E_z(x_{i+1}, y_j, t_n) - 2E_z(x_i, y_j, t_n) + E_z(x_{i-1}, y_j, t_n)}{(\Delta x)^2}, \quad (3)$$

$$\frac{\partial^2 E_z}{\partial y^2} \approx \frac{E_z(x_i, y_{j+1}, t_n) - 2E_z(x_i, y_j, t_n) + E_z(x_i, y_{j-1}, t_n)}{(\Delta y)^2}, \quad (4)$$

$$\frac{\partial^2 E_z}{\partial t^2} \approx \frac{E_z(x_i, y_j, t_{n+1}) - 2E_z(x_i, y_j, t_n) + E_z(x_i, y_j, t_{n-1})}{(\Delta t)^2}, \quad (5)$$

$$\frac{\partial E_z}{\partial \rho} \approx \frac{E_z(\rho_{i+1}, \varphi_j, t_n) - E_z(\rho_i, \varphi_j, t_n)}{\Delta \rho}, \quad (6)$$

$$\frac{\partial^2 E_z}{\partial \rho^2} \approx \frac{E_z(\rho_{i+1}, \varphi_j, t_n) - 2E_z(\rho_i, \varphi_j, t_n) + E_z(\rho_{i-1}, \varphi_j, t_n)}{(\Delta \rho)^2}, \quad (7)$$

$$\frac{\partial^2 E_z}{\partial \varphi^2} \approx \frac{E_z(\rho_i, \varphi_{j+1}, t_n) - 2E_z(\rho_i, \varphi_j, t_n) + E_z(\rho_i, \varphi_{j-1}, t_n)}{(\Delta \varphi)^2}, \quad (8)$$

where Δx , Δy , $\Delta \rho$ and $\Delta \varphi$ are the spatial differences, Δt is time difference, i , j and n are integer numbers.

The input and boundary conditions complete the equations (1, 2). The calculations are carried out for definite region, thus the wave function on the region boundaries is set equal to zero.

The signal on the waveguide input is set as

$$E_z(x_0 = 0, y, t) = E_0 \exp\left(-\frac{(y-y_0)^2}{a^2}\right) \sin(2\pi f t), \quad (9)$$

and the distribution of the E_z component of the electromagnetic field in interaction region of the input waveguides and ring microresonators is calculated as

$$E_z(\rho, \varphi, t) = E_1 \exp\left(-\frac{((\rho-\rho_0)\cos\varphi)^2}{a^2}\right) \sin(2\pi f t), \quad (10)$$

where E_0 is the amplitude of the input signal in the first waveguide, E_1 is amplitude of the signal passing into the ring microresonator from input waveguide, f is carrier frequency, values x_0 , y_0 , ρ_0 , φ_0 ($\varphi_0 = 0$) and a define the shape and spatial position of input Gaussian functions.

The spatial intervals Δx and Δy on coordinate axes is set less than the input radiation wavelength, and for the choice of discretization time step the Courant' generalized stability condition [11]

$$\Delta t \leq \frac{1}{c\sqrt{(1/\Delta x)^2 + (1/\Delta y)^2}} \quad (11)$$

is taken into account. The relation of variables for solving the wave Eq. (2) in cylindrical coordinates is set the similar way.

The coupling coefficient between input/output waveguides and ring microresonators is k_S and the one between two ring waveguides is k_R .

The resonance characteristic of the structure under consideration is defined as

$$T(\lambda) = \frac{I_{out}}{I_{in}} = \frac{E_{z, out}^2}{E_{z, in}^2}, \quad (12)$$

where $E_{z, in}$ and $E_{z, out}$ are the amplitudes and I_{in} and I_{out} are the intensities of the filter input and output signals, respectively.

In numerical modeling we use the next waveguide parameters: the length of straight input and output waveguides is $13 \mu\text{m}$, the waveguides thickness and width are $0.3 \mu\text{m}$, separation of input/output waveguides and ring microresonators is $0.2 \mu\text{m}$.

3. Results and Discussion

We have applied the algorithm described above to analyze the switching and resonance characteristics of the filter proposed. The results are plotted in Figs. 2–4.

Figure 2 shows the dependence of the FWHM (full width at half maximum) $\Delta\lambda$ of single resonance line on ring radius for filter with one (Fig. 2a) and two (Fig. 2b) ring

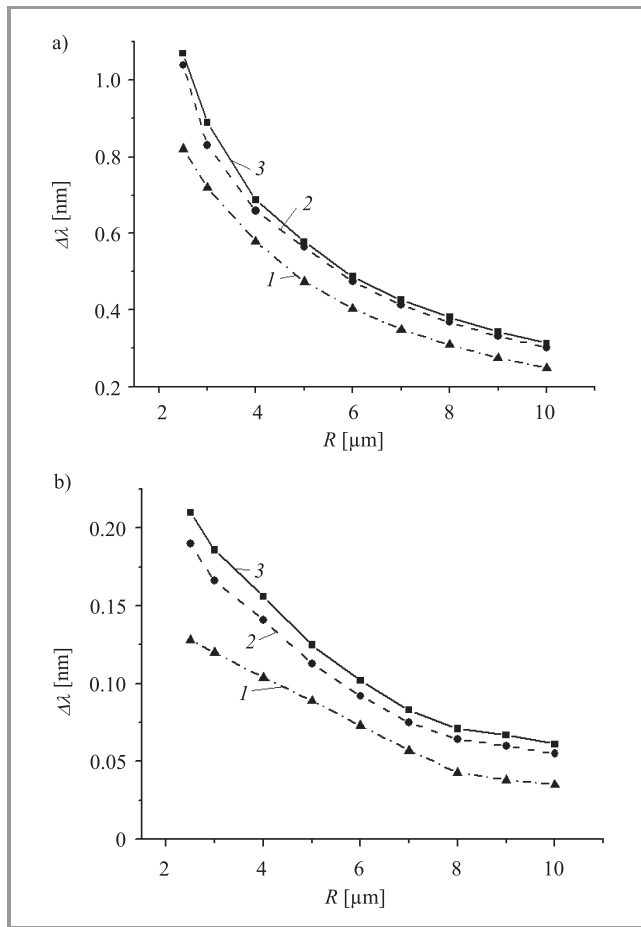

Fig. 2. Dependence of the FWHM $\Delta\lambda$ of the filter with one (a) and two (b) ring microresonators made from Si (1), GaAs (2) and InP (3) on ring radius R .

microresonators calculated for three semiconductor materials: Si ($n = 3.483$, curves 1), GaAs ($n = 3.2$, curves 2) and InP ($n = 3.172$, curves 3).

The passband FWHM of the filter made from GaAs on the base of one ring microresonator with radius $R = 2.5 \mu\text{m}$ is 1.04 nm (curve 1 in Fig. 2). This result is in a good agreement with the one reported in [10]. The passband width of the same filter on the level of 0.1 of the maximum is 1.72 nm . Thus for effective switching the resonance band it is necessary to shift the wavelength of its maximum on the spectral interval of the order of 1.7 nm . Our calculations show that for such shifting the passband of the filter with ring radius $R = 2.5 \mu\text{m}$ it is necessary to change the waveguide material index in second digit after comma, that is practically unrealizable [5, 8]. In practice, in controllable integrated optical filters from GaAs the real changing the free carrier density can be as high as $2.5 \cdot 10^{18} \text{ cm}^{-3}$ [5]. This results in variation of waveguide material index on the value up to $\Delta n = 0.003$. For filter with ring radius $R = 10 \mu\text{m}$ the passband width on the level of 0.1 of the maximum is 0.48 nm . That means that in order to shift the resonance passband on the value comparable with its width the waveguide effective index has to be changed on the value $\Delta n \approx 0.002$, which can be realize in practice [5, 8]. The similar conclusion is valid for the filter made from Si and InP, in which the change of free carrier density on the value $5 \cdot 10^{18} \text{ cm}^{-3}$ [12] and $3 \cdot 10^{18} \text{ cm}^{-3}$ [13], respectively, leads to index variation Δn approximately equal 0.004 and 0.003 [13, 14].

The passband control efficiency of the integrated optical filter based on one and two optically coupled microresonators is estimated by the value of the ratio η of maximal intensities of its output signals in two positions: $\eta = I_{on}/I_{off}$, where I_{on} and I_{off} are the maximal intensities corresponding the open and closed filter conditions, respectively. Our calculations show that the filters with one resonator with the radius in the range $R = 2.5 \dots 10 \mu\text{m}$ can't be used in the most of practical applications because of the small value of η .

Figure 3 shows the dependence of the ratio η on Δn value for the filters composed of single-ring resonator with $R = 14 \mu\text{m}$ (Fig. 3a) and two-ring resonator with $R = 10 \mu\text{m}$ (Fig. 3b) made from Si ($n = 3.483$, curves 1), GaAs ($n = 3.2$, curves 2) and InP ($n = 3.172$, curves 3). The single-ring microresonator and two-rings filter of such size occupies the same substrate area.

The modeling of the spectral characteristic of the filter composed of two-coupled microresonators on the base of GaAs and Si shows that their resonance passband width is narrower in more than 4 times as compared with single-ring filter made from the same materials and with the same radii (see Fig. 2).

Figure 4 shows the calculated resonance passbands of the filters composed of two similar optically coupled microresonators from Si (Fig. 4a), GaAs (Fig. 4b) and InP (Fig. 4c) in initial condition (curves 1) and in switched condition ($\Delta n = 0.004$, curves 2). The dependence of

the ratio η on the variation of the material indices Δn for cases of Fig. 4 is presented on Fig. 3b by curves 1, 2 and 3, respectively. For the filters under consideration the high value η exceeding 10^5 is achieved for Δn equal $4 \cdot 10^{-4}$ (curve 3) for $R = 10 \mu\text{m}$.

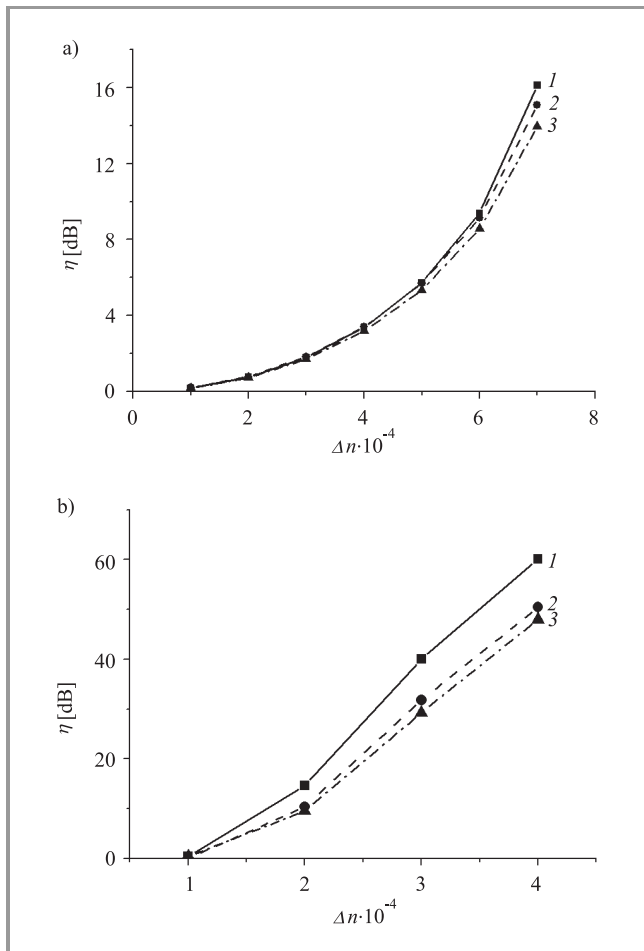

Fig. 3. Dependence of the ratio η on Δn value for the filter with one ring microresonator with $R = 14 \mu\text{m}$ (a) and two (b) ring microresonators with $R = 10 \mu\text{m}$ made from Si (1), GaAs (2) and InP (3).

The speed of response of the filter under consideration is defined by the sum of the transition time of the output signal and relaxation (recombination) time of the charge carriers. The signal establishing in single-ring microresonator is accomplished in approximately 29 passing the radiation through the microresonator ring with radius $R = 10 \mu\text{m}$ and coupling coefficients between straight and ring waveguides equal 0.5 [7]. That amounts approximately 20.4 ps for GaAs, 18.8 ps for Si and 18.6 ps for InP. The output signal establishing in the filter from two coupled microresonators is accomplished in 26.3, 24.1 and 23.9 ps for GaAs, Si and InP, respectively.

The relaxation (recombination) time of charge carriers in Si, GaAs and InP is 23 ps [15], 0.4 ps [16] and 0.2 ps [17], respectively. Thus the maximal signal-repetition frequency

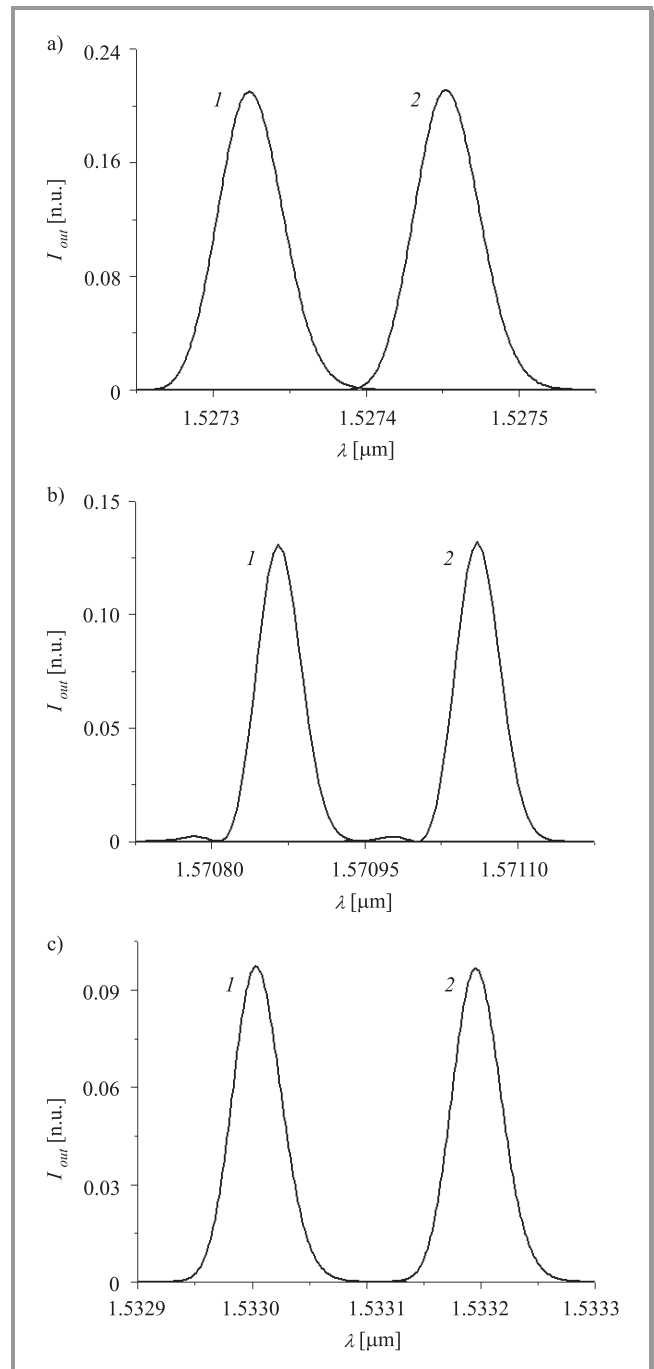

Fig. 4. Resonance passbands of the filters composed from two similar optically coupled microresonators with $R = 10 \mu\text{m}$ made from Si (a) for $n = 3.483$ (1) and $n = 3.4833$ (2); GaAs (b) for $n = 3.2$ (1) and $n = 3.2004$ (2); and InP (c) for $n = 3.172$ (1) and $n = 3.1724$ (2).

for optical filter on the base of one microresonator ring is equal to 12.0 GHz for silicon waveguide, 24.0 GHz for gallium arsenide waveguide and 26.6 GHz for indium phosphide waveguide. For the filter composed of two optically coupled rings with radius $10 \mu\text{m}$ the maximal signal-repetition rates are smaller: 10.8, 19.3 and 21.3 GHz for Si, GaAs and InP, respectively.

4. Conclusions

We propose the numerical modeling the controllable optical filter composed of two optically coupled semiconductor waveguide ring microresonators disposed between two straight input/output waveguides. We compare the passband width and shift of maximums of resonance bands of the filters made of different semiconductor materials in dependence on variation of their refractive indices. It is shown that the signal-to-noise ratio on the output of the filter proposed could be as high as 50 dB for index variation 0.004, which can be realized in practice.

Speed of response of the filter made from GaAs or InP is about 20 GHz and in two times larger than the pulse-repetition rate of silicon filter (about 10 GHz). However, Si is relative cheap material and its technology is well developed with low rejection rate. Therefore, gallium arsenide or indium phosphide filters could be used for high-performance information processing while in mass production optoelectronic interfaces one can apply the silicon filters.

The filter passband width on the level of 0.1 of maximum is of the order of 0.1 nm. The bandwidth of element base of modern optical fiber communication lines is 32 nm. Thus the use of such filters allows realizing the parallel data transmission over the 160 channels in single fiber. When the speed of response of single channel is 10 Gbit/s the communication line capacity could achieve 1.6 Tbit/s.

The proposed optical filter can contribute to advancing the optical fiber communication lines using WDM and DWDM technologies and operating on multigigabit and terabit velocities.

Acknowledgements

Alexander Esman, Vladimir Kuleshov and Vladimir Pilipovich thank the Belarussian Fund of Fundamental Research (grant F07MS-004) for the financial support of this work. The authors thank the European Project COST Action MP0702 "Towards functional sub-wavelength photonic structures" for stimulating interactions.

References

- [1] I. A. Mamzelev, V. M. Malafeev, A. D. Snegov, and L. V. Yurasova, *Technologies and Equipment*. Moscow: Eko-Trends, 2005.
- [2] V. E. Kuznetsov *et al.*, "Method of redundancy in phase-locked optical communication line with system of spectral multiplex". Patent of Russian Federation, no. 2307469.
- [3] V. G. Tatsenko and A. K. Shishov, "Systems with channel spectral multiplexing (WDM and DWDM systems) in optical fiber systems for communication of information". Part 2, *Tele-Sputnik*, no. 2, pp. 24–29, 2004.
- [4] A. V. Shmal'ko, "Systems for spectral multiplex of optical channels", *Bull. Commun.*, no. 4, pp. 162–170, 2002.

- [5] T. A. Ibrahim *et al.*, "Lightwave switching in semiconductor microring devices by free carrier injection", *J. Lightw. Technol.*, vol. 21, no. 12, pp. 2997–3003, 2003.
- [6] B. E. Little *et al.*, "Ultra-compact Si-SiO₂ microring resonator optical channel dropping filters", *IEEE Photon. Technol. Lett.*, vol. 10, no. 4, pp. 549–551, 1998.
- [7] I. A. Goncharenko, A. K. Esman, V. K. Kuleshov, and V. A. Pilipovich, "Optical broadband analog-digital conversion on the base of microring resonator", *Opt. Commun.*, vol. 257, no. 1, pp. 54–61, 2006.
- [8] S. Abdalla *et al.*, "Carrier injection-based digital optical switch with reconfigurable output waveguide arms", *IEEE Photon. Technol. Lett.*, vol. 16, no. 4, pp. 1038–1040, 2004.
- [9] S. T. Chu and S. K. Chaudhuri, "Numerical modeling the electromagnetic field distribution in the waveguide based on photonic crystal", *J. Lightw. Technol.*, vol. 7, pp. 2033–2038, 1989.
- [10] A. S. Loginov and A. S. Majorov, "Numerical modeling the characteristics of selective integrated optical elements taking into account the loss compensation", *J. Radioelectron.*, no. 3, pp. 17–21, 2007.
- [11] N. N. Kalitkin, *Numerical Methods*. Moscow: Nauka, 1978, pp. 425–439.
- [12] M. S. Bressler, O. B. Gusev, and E. I. Terukov, "Silica edge electroluminescent: heterostructure amorphous silicon-crystalline silicon", *Sol. Phys.*, vol. 46, no. 1, pp. 18–20, 2004.
- [13] M. V. Kotlyar, L. O'Faolain, A. B. Krysa, and T. F. Krauss, "Electrooptic tuning of InP-base microphotonic Fabry-Perot filters", *J. Lightw. Technol.*, vol. 23, no. 6, pp. 2169–2174, 2005.
- [14] C. Manolatou and M. Lipson, "All-optical silicon modulators based on carrier injection by two-photon absorption", *J. Lightw. Technol.*, vol. 24, no. 3, pp. 1433–1439, 2006.
- [15] F. Y. Gardes *et al.*, "Micrometer size polarization independent depletion-type photonic modulator in silicon on insulator", *Opt. Expr.*, vol. 15, no. 9, pp. 5879–5884, 2007.
- [16] S. S. Strelchenko and V. V. Lebedev, *Compounds A³B⁵*. Handbook. Moscow: Metallurgy, 1984, p. 60.
- [17] A. S. Tager, "Prospects of application of indium phosphide in microwave semiconductor electronics", in *Indium Phosphide in Semiconductor Electronics*, S. I. Radautsan, Ed. Kishinev: Stiintza, 1988, pp. 120–132.



Igor A. Goncharenko was born in Minsk, Belarus. He received M.Sc. degree from Belarussian State University in 1981, Ph.D. degree in physics and mathematics from the USSR Academy of Sciences (Moscow) in 1985 and Dr.Sc. degree from the National Academy of Sciences of Belarus (Minsk) in 2001. Since September 2007 he

takes up the position of Professor of the Department of Natural Sciences in the Institute for Command Engineers of the Ministry of Emergencies of the Republic of Belarus and part time Professor position in Belarussian National Technical University. His fields of investigation include theory of complicated optical fibre and waveguide devices, optical information processing.

e-mail: Igor02@tut.by
Institute for Command Engineers
of the Ministry of Emergencies of the Republic of Belarus
Department of Natural Sciences
Mashinostroiteley st 25
220118 Minsk, Belarus

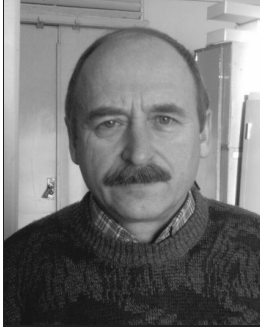

Alexander Konstantinovich Esman was born in 1951. He got his M.Sc. from Belarusian State University in 1973 and Ph.D. in physical and mathematical sciences in 2003. He is a major researcher of the B. I. Stepanov Institute of Physics of the National Academy of Sciences of Belarus. His concept of scientific research is

optical data processing.
e-mail: lomoi@inel.bas-net.by
Institute of Physics
National Academy of Sciences
22 Logoisky Trakt
220090 Minsk, Belarus

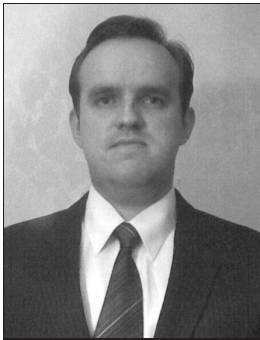

Grigory Lyutsianovich Zykov was born in 1980. He got his M.Sc. from Gomel State University in 2002. He has been a candidate of technical sciences since 2007. He is a researcher of the B. I. Stepanov Institute of Physics of the National Academy of Sciences of Belarus. His concept of scientific research is optical data processing, simulation of the physical processes in the dielectric and semiconductor materials.

optical data processing, simulation of the physical processes in the dielectric and semiconductor materials.
e-mail: lomoi@inel.bas-net.by
Institute of Physics
National Academy of Sciences
22 Logoisky Trakt
220090 Minsk, Belarus



Vladimir Konstantinovich Kuleshov was born in 1951. He got his M.Sc. from Belarusian State University in 1973. He has been a candidate of technical sciences since 1984. He is a leading researcher of the B. I. Stepanov Institute of Physics of the National Academy of Sciences of Belarus. His concept of scientific re-

search is optical data processing and elements of integrated computer engineering.

e-mail: lomoi@inel.bas-net.by
Institute of Physics
National Academy of Sciences
22 Logoisky Trakt
220090 Minsk, Belarus



Marian Marciniak graduated in solid state physics from Marie Curie-Skłodowska University in Lublin, Poland, in 1977. He holds a Ph.D. degree in optoelectronics (1989), and a Doctor of Sciences (Habilitation) degree in physics/optics (1997). Actually he is the Head of Department of Transmission and Optical Technologies at the

National Institute of Telecommunications. He authored 280 publications, including a number of invited conference presentations. He serves as a Honorary International Advisor to the George Green Institute for Electromagnetics Research, University of Nottingham, UK. He serves as the Chairman of the Management Committee of COST Action MP0702 "Towards functional sub-wavelength photonic structures".

e-mail: M.Marciniak@itl.waw.pl
e-mail: marian.marciniak@ieee.org
National Institute of Telecommunications
Szachowa st 1
04-894 Warsaw, Poland

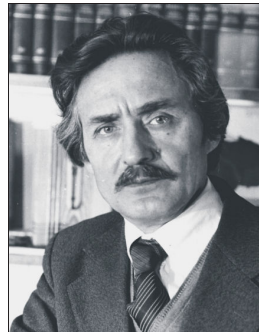

Vladimir Antonovich Pilipovich was born in Gomel region, Belarus, in 1931. He received M.Sc. degree from Belarussian State University in 1954, Ph.D. degree in physics and mathematics in 1959 and Dr.Sc. degree in 1972. He has the rank of Professor in physics and is a Member of the National Academy of Sciences of Belarus (NASB). He has worked in NASB since 1957. From 1973 to 1998 he was a Director of the Institute of Electronics. At present he is a Chief Research Fellow of the Institute of Physics NASB. He is a co-author of more than 300 scientific publications including 3 monographs. Field of his scientific interests includes lasers and laser physics, optoelectronics and optical information processing. He is a Member of the IEEE and SPIE.

He has worked in NASB since 1957. From 1973 to 1998 he was a Director of the Institute of Electronics. At present he is a Chief Research Fellow of the Institute of Physics NASB. He is a co-author of more than 300 scientific publications including 3 monographs. Field of his scientific interests includes lasers and laser physics, optoelectronics and optical information processing. He is a Member of the IEEE and SPIE.

e-mail: lomoi@inel.bas-net.by
Institute of Physics
National Academy of Sciences
22 Logoisky Trakt
220090 Minsk, Belarus