

# High-Frequency Power Amplitude Modulators with Class-E Tuned Amplifiers

Juliusz Modzelewski and Mirosław Mikołajewski

**Abstract**—A high-frequency power amplifier used in a drain amplitude modulator must have linear dependence of output HF voltage  $V_o$  versus its supply voltage  $V_{DD}$ . This condition essential for obtaining low-level envelope distortions is met by a theoretical class-E amplifier with a linear shunt capacitance of the switch. In this paper the influence of non-linear output capacitance of the transistor in the class-E amplifier on its  $V_o(V_{DD})$  characteristic is analyzed using PSPICE simulations of the amplifiers operating at frequencies 0.5 MHz, 5 MHz and 7 MHz. These simulations have proven that distortions of the  $V_o(V_{DD})$  characteristic caused by non-linear output capacitance of the transistor are only slight for all analyzed amplifiers, even for the 7 MHz amplifier without the external (linear) shunt capacitance. In contrast, the decrease of power efficiency of the class-E amplifier resulting from this effect can be significant even by 40%.

**Keywords**— high-efficiency amplitude modulators, non-ZVS operation, optimum operation, PSPICE simulations, sub-optimum operation.

## 1. Introduction

Power amplitude modulators are commonly used as the output stage of broadcasting and radio-communication transmitters with amplitude modulation (AM) as well as in special high-efficiency linear amplifiers utilizing the envelope elimination and restoration (EER) method.

In the basic power AM modulator the amplitude of its high-frequency (HF) output signal is modulated by varying the supply voltage of a HF power amplifier. This method of amplitude modulation is called the drain (collector or anode) modulation. The HF power amplifier applied in the drain modulator must fulfil two important requirements. First of all, to avoid non-linear distortions of the output-signal envelope, the amplitude  $V_o$  of the output voltage in this amplifier must be directly proportional to its supply voltage  $V_{DD}$ :

$$V_o = k \cdot V_{DD}, \quad (1)$$

where  $k = \text{const.}$ ,  $v_o(t) = V_o \sin(2\pi f_c t)$  is the output voltage,  $f_c$  is the carrier frequency. The relationship  $V_o(V_{DD})$  of the amplifier is called the amplitude-modulation characteristic. Another highly desirable feature of such the AM-modulated amplifier is its high efficiency in the whole range of output voltage  $0 - V_{o\text{max}}$  to decrease power losses in the AM modulator. Thus, cost, dimensions, and weight of the modulators can be reduced, which is very important particularly in mobile, battery-operated transmitters.

Therefore, the dependence of efficiency on the supply voltage  $\eta(V_{DD})$  is also a very important characteristic of the AM-modulated HF amplifier.

Similar problems arise in industrial electronics when HF power regulation is needed, e.g., in inductive or dielectric heaters. In these applications high-efficiency is a basic feature of the regulated power amplifier. The linearity of  $V_o(V_{DD})$  is desirable but not required.

The class-E tuned power amplifier (Fig. 1a) with its high efficiency as well as a highly linear amplitude modulation characteristic theoretically satisfies the condition (1), which makes it an attractive choice for a high-efficiency amplitude-modulated transmitter. However, in the real-world class-E amplifiers there are phenomena disturbing the drain amplitude modulation [1], [2]. Above all, the quality of the amplitude modulation by varying the supply voltage deteriorates with the increase of the modulating signal frequency. It results from the fact that, firstly, the large (theoretically infinite) inductance of the RF power-supply choke  $L_{CH}$  limits the available rate of change of the output-HF-voltage envelope. Therefore the modulation depth  $m$  decreases with increase of the modulating-signal frequency (linear distortion). Secondly, the envelope of the output HF signal is non-linearly distorted because the lower and upper sideband components of the AM signal are transmitted by the series resonant branch  $L_{SR}, C_{SR}, R_L$  (Fig. 1) with different gains and phase shifts. This effect is caused by the fact that the branch  $L_{SR}, C_{SR}$  is not in resonance at the carrier frequency  $f_c$  and its impedance is inductive. The non-linear distortions become worse with the increase of the loaded quality factor of the  $L_{SR}, C_{SR}, R_L$  branch, with the increase of the ratio of the modulating-signal bandwidth to the carrier frequency  $f_c$ , and with the depth of modulation  $m$  [3]. These distortions can be high, up to 12% [1].

The non-linear distortions of the envelope can be also caused by non-linearities of the static characteristic of the drain modulation  $V_o(V_{DD})$  in real class-E amplifiers. For small values of the supply voltage  $V_{DD}$  the non-linearity of  $V_o(V_{DD})$  is caused by direct transmission of the input HF signal to the output by the reverse drain-gate capacitance  $C_{rss}$  of the transistor [3]. Hence, the amplitude  $V_o$  is non-zero for  $V_{DD} = 0$ . This effect increases with the operating frequency of the amplifier.

For a high operating frequency the non-linearity of the amplifier characteristic  $V_o(V_{DD})$  can be also caused by the non-linear output capacitance  $C_{oss}$  of the transistor because this capacitance forms most of the shunt capacitance

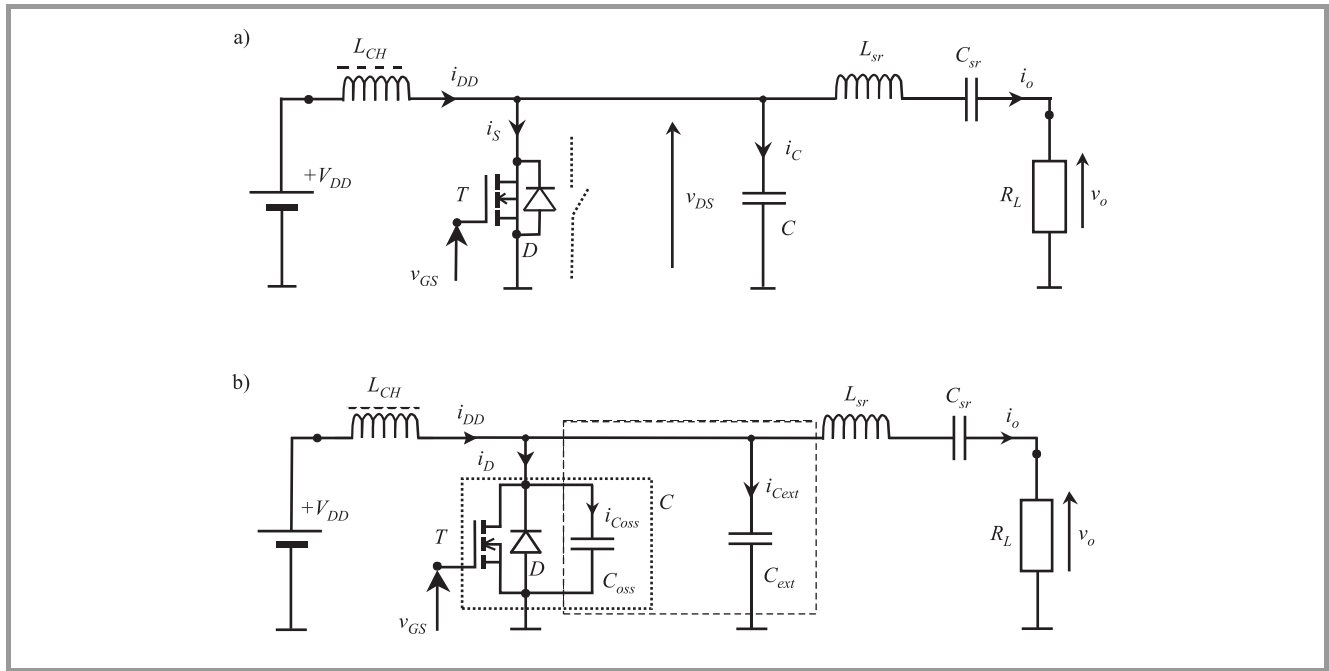

Fig. 1. Class-E tuned power amplifier: (a) basic circuit; (b) components of the shunt capacitance of the switch ( $C = C_{ext} + C_{oss}$ ).

$C = C_{ext} + C_{oss}$  in the class-E amplifier (Fig. 1b). Then the variations of the supply voltage  $V_{DD}$  cause substantial changes in the value of  $C$ , which increases considerably with decreasing drain-source voltage (Fig. 2). This modifies

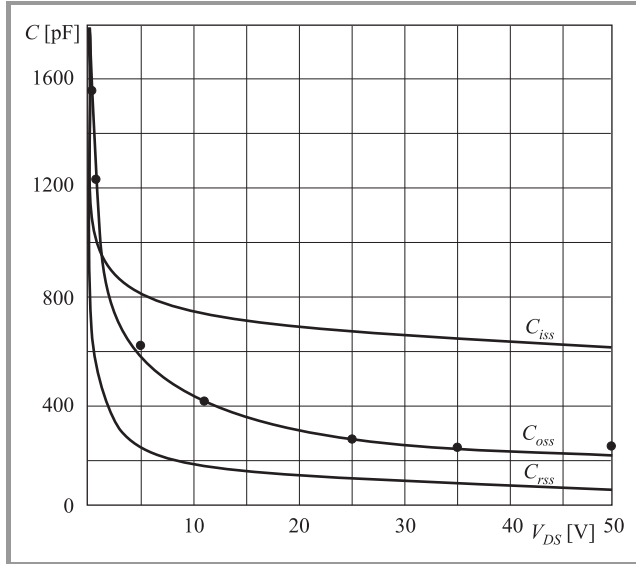

Fig. 2. Capacitances  $C_{iss}$ ,  $C_{oss}$ ,  $C_{rss}$  of transistor IRF530 versus drain-to-source voltage [4] and the values of  $C_{oss}$  extracted from the modified PSPICE model (●).

in a significant way the operation of the class-E amplifier because both decrease and increase of the supply voltage mistune this amplifier changing shapes of the drain voltage and current waveforms. Hence, the function  $V_o(V_{DD})$  of the class-E amplifier without external shunt capacitance

may be non-linear. Besides, for certain ranges of  $V_{DD}$  the class-E amplifier may not operate optimally and its efficiency become worse. Moreover, the resonant frequency of amplifier parallel resonant circuit  $C - L_{sr} - C_{sr} - R_L$  also changes with  $V_{DD}$  causing unwanted amplitude and phase modulation of the amplifier output signal.

The aim of this paper is to analyze effects of non-linearity of the transistor output capacitance  $C_{oss}$  for the drain-modulation static characteristic  $V_o(V_{DD})$  and drain-efficiency static characteristic  $\eta_D(V_{DD})$  of the HF class-E amplifier. It is necessary to compare these characteristics determined for amplifiers with the same transistor but operating at different frequencies, i.e.:

- low-frequency amplifier with approximately linear shunt capacitance ( $C_{ext} \gg C_{oss}$ );
- medium-frequency amplifier with noticeably non-linear shunt capacitance ( $C_{ext} \approx C_{oss}$ );
- high-frequency amplifier with maximally non-linear shunt capacitance ( $C_{ext} \approx 0$ ).

This analysis can be done by PSPICE (Personal Computer Simulation Program with Integrated Circuit Emphasis) simulations. In the analyzed class-E amplifiers the transistor IRF530 has been applied.

## 2. Modes of Operation of the Class-E Amplifier

The class-E amplifier is a high-efficiency switch-mode resonant amplifier. Its high efficiency results from very much

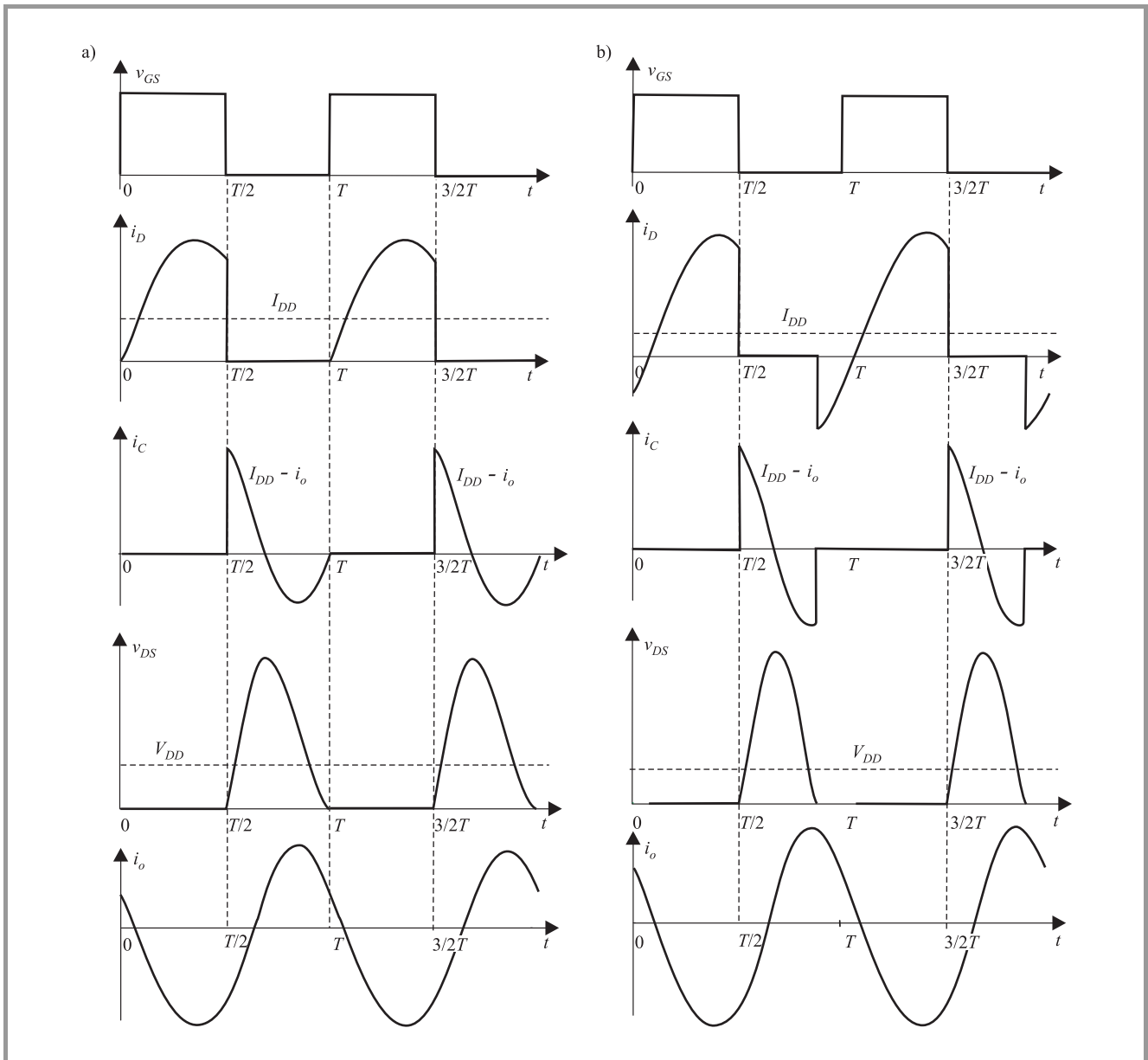

Fig. 3. Optimum (a) and sub-optimum (b) operation of the class-E amplifier.

reduced power losses in the transistor. To achieve high efficiency, firstly, the transistor in the amplifier operates as a switch to reduce power losses caused by its conducted current. Secondly, switching losses resulting from a finite transition time between on and off states of the transistor switch are also reduced. The decrease of switching losses is obtained by shaping the drain current and drain voltage waveforms of the transistor by the resonant circuit in the amplifier to achieve so-called zero-voltage switching (ZVS) and/or zero-current switching (ZCS) operation of the transistor switch. The ZVS and/or ZCS operation means that at the switching moments the drain-source voltage of the transistor is zero and/or its drain current is zero as well. Then the instantaneous value of drain power loss in the transistor switch at its switching moments is zero or is very much reduced.

The class-E amplifier (Fig. 1) consists of a choke  $L_{CH}$  supplying a DC current  $I_{DD}$  to the circuit, transistor switch  $T$  and a parallel-series resonant circuit  $C - L_{sr} - C_{sr}$  with load resistance  $R_L$ . When the switch  $T$  is on it conducts the supply current  $I_{DD}$  and a sinusoidal current  $i_o$  of the series resonant circuit  $L_{sr} - C_{sr} - R_L$ . Then the power losses in the transistor depend on its conducted current  $i_D = I_{DD} - i_o$  and the transistor on-resistance. When the switch is off, the current  $I_{DD} - i_o$ , at first charges (for  $I_{DD} - i_o > 0$ ) and then discharges (for  $I_{DD} - i_o < 0$ ) the parallel capacitance  $C$  shaping the  $v_{DS}$  waveform. The maximum value of  $v_{DS}$  occurs for  $I_{DD} - i_o = 0$ .

In the operation of the amplifier three different modes can be identified, which are presented in Figs. 3 and 4 [5]. Figure 3a shows the waveforms in the class-E amplifier

for its optimum operation. The switch  $T$  turns on at zero drain voltage and zero drain current (i.e.,  $v_{DS}(t=0) = 0$  and  $Cdv_{DS}/dt|_{t=0} = i_D(t=0) = 0$ ). Therefore there is no switching loss at the transistor turn on. When the switch  $T$  turns off there is a jump change in the drain current  $i_D$ , but the drain voltage rises slowly from zero, which results in low switching losses. This mode is characterized by the highest efficiency (practical values of 98% are achieved), and the amplifier is usually designed to work in this mode. The maximum value of drain current and drain voltage are then typically  $I_{Dmax} = 2.78 I_{DD}$ ,  $V_{DSmax} = 3.61 V_{DD}$ , respectively (for loaded quality factor of the  $L_{sr} - C_{sr} - R_L$  circuit equal to  $Q_l = 5$  [6]).

Waveforms for the sub-optimum operation of the class-E amplifier are given in Fig. 3b. In this mode of operation the shunt capacitor  $C$  is discharged to zero before transistor  $T$  is turned on by the driving signal  $v_{GS}$ . Then the voltage  $v_{DS}$  becomes negative and the anti-parallel diode  $D$  of the transistor turns on conducting the negative current  $i_D = I_{DD} - i_o$  and maintaining  $v_{DS}$  voltage close to zero till the turn-on instance of the transistor. Thus, the transistor  $T$  turns on and off at ZVS and non-ZCS conditions. The use of diode  $D$  allows avoiding a significant nega-

tive drain voltage appearing across the transistor, which would cause high turn-on switching losses. The amplifier efficiency in the sub-optimum mode is lower than in the optimum mode but still can be high up to 95%. This operation mode can be obtained by decreasing load resistance  $R_l$ . The maximum values of drain current and drain voltage in the sub-optimum mode are higher than in the optimum mode ( $V_{DSmax}$  can 4.6 times exceed  $V_{DD}$ ) even though the output power is lower.

Figure 4 illustrates non-ZVS operation of the class-E amplifier (so-called non-optimum operation). In this mode of operation the transistor turns on when the drain voltage  $v_{DS}$  is non-zero. This results in high turn-on switching losses due to the current spike in the drain current  $i_D$  caused by rapid discharging of the shunt capacitor  $C$ . The efficiency in this mode of operation can be much decreased and power losses in the transistor can be high requiring proper cooling of the transistor if one expects the non-ZVS mode to occur in the amplifier operation. This mode of operation of the class-E amplifier is obtained by, e.g., increasing load resistance above its optimum-mode value. The maximum values of  $I_{Dmax}$  and  $V_{Dmax}$  as well as the output power are lower than in the optimum mode.

### 3. Model of the Output Capacitance of Power MOSFETs

The parasitic output capacitance  $C_{oss}$  of power MOSFETs is mainly the capacitance of the reverse biased p-n junction body diode. Therefore the small-signal value of  $C_{oss}$  can be expressed by:

$$C_{oss} \cong C_{j0} \left(1 + \frac{v_{DS}}{V_{BI}}\right)^{-MJ}, \quad (2)$$

where:  $C_{j0}$  is the zero-bias capacitance,  $V_{BI}$  is the built-in potential of the body-diode junction,  $MJ$  is the grading coefficient of this junction ( $MJ = 0.5$  for the step junction) [7]–[10]. In the basic PSPICE models of power MOSFETs [11] it is assumed  $MJ = 0.5$  and value of  $C_{j0}$  is adjusted to obtain correct values of  $C_{oss}$  for medium values of  $v_{DS}$ . Thus, these models cannot be used for exact simulations of the class-E amplifier without external drain-source shunt capacitance of the transistor.

In [8] it was proven that the PSPICE model can describe correctly the power-MOSFET output capacitance as a function of  $v_{DS}$  if the grading coefficient is increased to  $MJ = 0.77$ . Therefore we modified the basic PSPICE model of the transistor IRF530 [11] assuming  $MJ = 0.77$ . For the drain-body junction zero-bias capacitance increased to  $C_{bd} = 2$  nF (instead of 1.151 nF) the function  $C_{oss}(V_{DS})$  extracted from PSPICE model is approximately equal to the data published by the manufacturer [4] – see Fig. 2.

### 4. Analyzed Class-E Amplifiers

It was assumed that the analyzed low-, medium- and high-frequency class-E amplifiers have the following parameters:

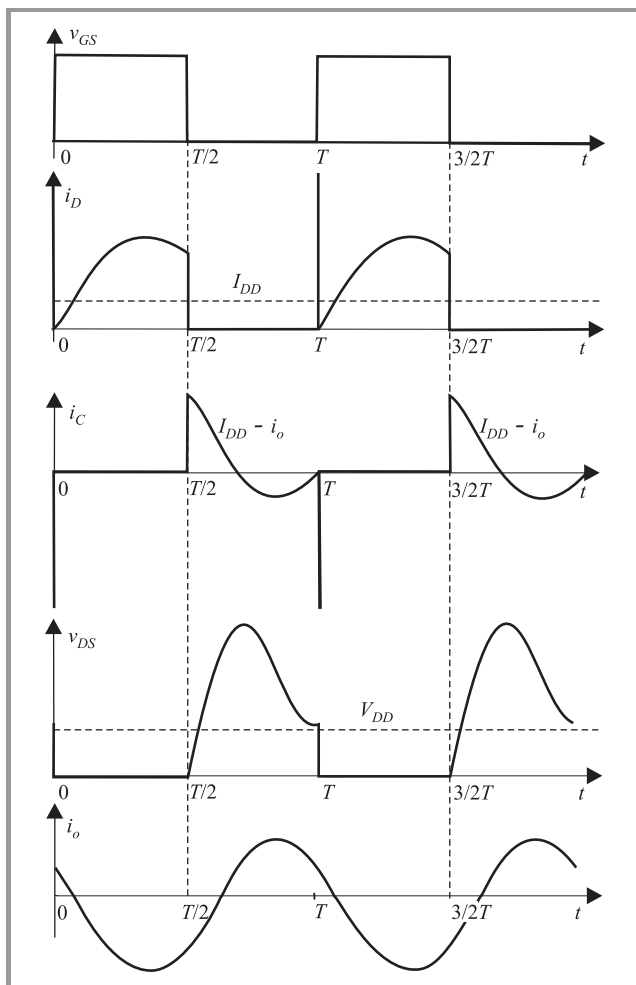

Fig. 4. Non-ZVS (non-optimum) operation of the class-E amplifier.

- switch duty cycle  $D = 0.5$ ;
- maximum supply voltage  $V_{DD\max} = 12$  V;
- maximum output power  $P_{o\max} = 12$  W;
- loaded quality factor of the series resonant circuit  $Q_l = 5$ .

For  $Q_l = 5$  the load resistance of these amplifiers is equal to  $R_L = 0.5249(V_{DD\max})^2/P_{o\max}$  [6]. Values of the resonant-circuit components (see Fig. 1a) for a given operating frequency  $f_o$  are:  $L_{sr} = 5.673R_L/(2\pi f_o)$ ,  $C_{sr} = 0.2269/(2\pi f_o R_L)$ ,  $C = 0.2067/(2\pi f_o R_L)$  [6]. The operating frequency  $f_o$  of the low-, medium- and high-frequency class-E amplifiers with the chosen transistor IRF530 can be assumed as 0.5 MHz, 5 MHz, and 7 MHz, respectively. The calculated values of  $R_L$  and  $L_{sr}$ ,  $C_{sr}$ ,  $C$  are presented in Table 1.

Table 1  
Components of the analyzed class-E amplifiers

$f_o$ [MHz]	$L_{sr}$ [ $\mu$ H]	$C_{sr}$ [nF]	$C$ [nF]	$R_L$ [ $\Omega$ ]	$L_{CH}$ [ $\mu$ H]	$C_{ext}$ [nF]
0.5	11.374	11.47	10.45	6.299	430	10.1
5	1.1374	1.147	1.045	6.299	43	0.497
7	0.8124	0.8193	0.7464	6.299	30.7	0.020

## 5. PSPICE Simulations

For PSPICE simulations it was assumed that the analyzed class-E amplifiers are driven by the 0.5 duty cycle square-wave generator consisting of the 10 V-peak-to-peak unipolar voltage source and the 3.5  $\Omega$  internal resistance. This source and resistance are an equivalent circuit of the integrated driver MIC 4423 applied in experimental amplifiers.

In the first step of simulation of the each amplifier (0.5 MHz, 5 MHz, and 7 MHz) the external shunt capacitance  $C_{ext}$  (Fig. 1b) was adjusted to ensure the optimum operation (i.e., with ZVS and ZCS turn on of the transistor IRF530) for  $V_{DD} = 12$  V. The obtained values of  $C_{ext}$  are presented in Table 1. It should be noted that in the 7 MHz class-E amplifier (with the very low  $C_{ext}$  and non-linear shunt capacitance of the switch) to ensure the optimum operation (Fig. 3a) it was necessary to adjust the duty cycle of the driving generator to  $D = 52\%$  [12]. Inductance of the choke  $L_{CH}$  (Table 1) was chosen to obtain approximately constant supply current of the amplifiers. Drain voltage and current waveforms in the 0.5 MHz, 5 MHz, and 7 MHz amplifiers for  $V_{DD} = 12$  V are presented in Figs. 5a, 7a, and 9a, respectively.

The carried out simulations have confirmed that for the sufficiently low supply voltage  $V_{DD}$  the each of the analyzed class-E amplifiers operates in the non-ZVS mode (Figs. 5b, 7b, and 9b). It results from the fact that the output capacitance of IRF530 strongly increases for low  $V_{DS}$  (Fig. 2). Obviously, in the 0.5 MHz amplifier this effect can be observed only at the very low supply voltage ( $V_{DD} \leq 1$  V). In contrast, in the 7 MHz amplifiers

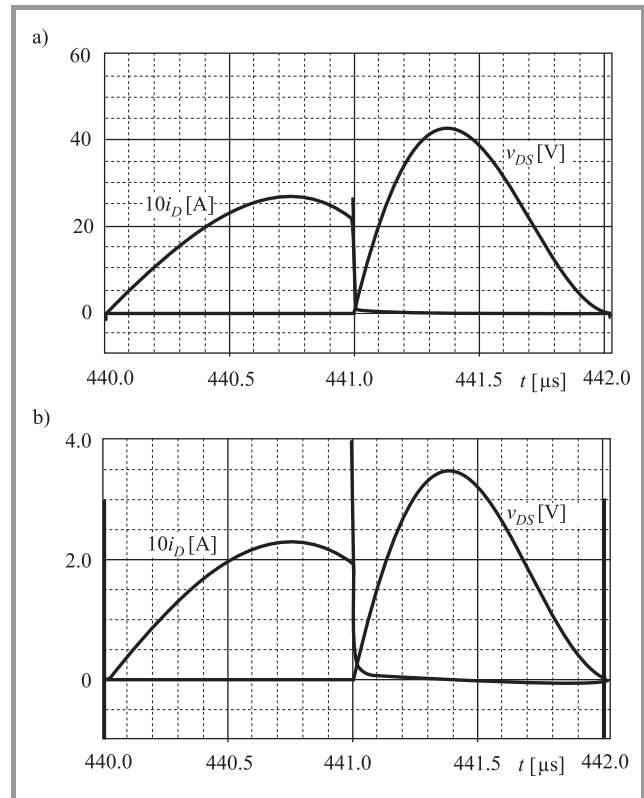

Fig. 5. Drain-source voltage  $v_{DS}$  and drain current  $i_D$  in the 0.5 MHz class-E amplifier (PSPICE simulation): (a) full supply voltage  $V_{DD} = 12$  V; (b) reduced supply voltage  $V_{DD} = 1$  V.

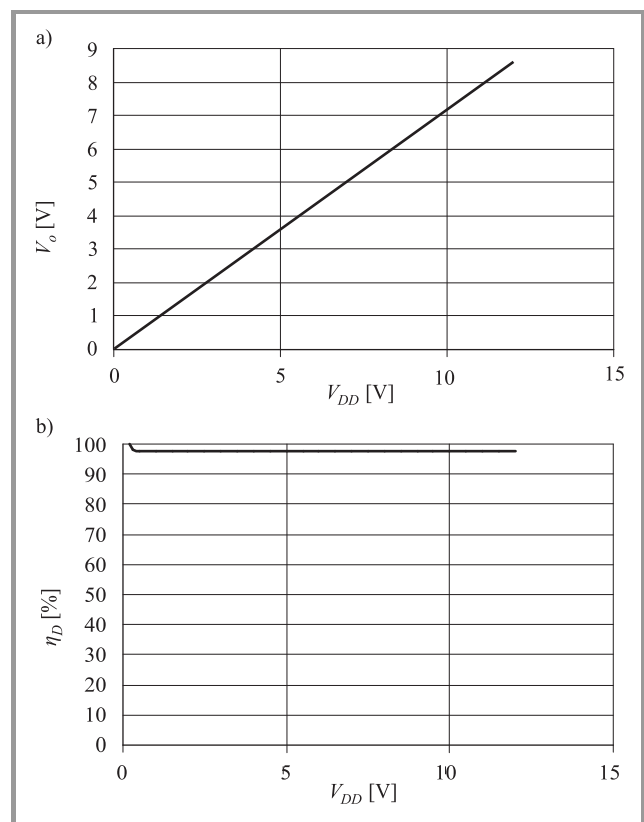

Fig. 6. Characteristic curves (a)  $V_o(V_{DD})$  and (b)  $\eta_D(V_{DD})$  of the 0.5 MHz class-E amplifier obtained by PSPICE simulations.

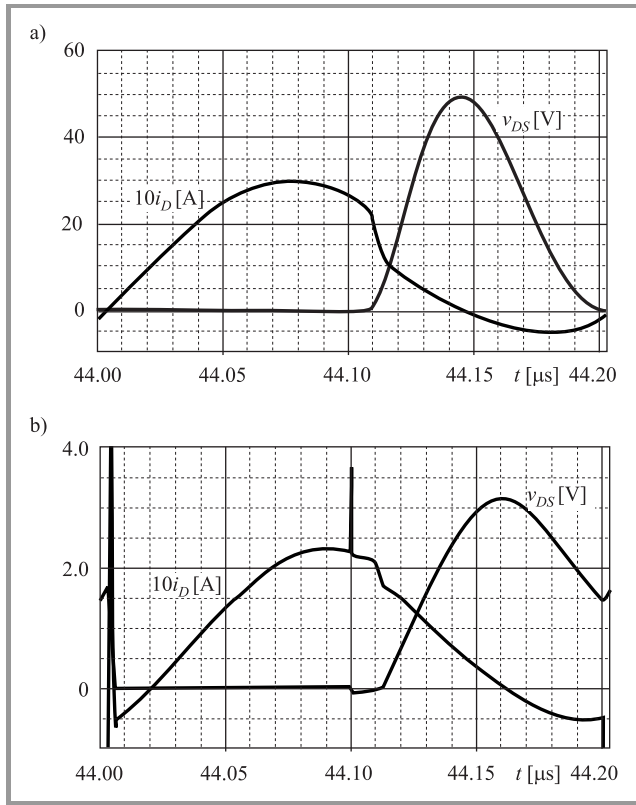

Fig. 7. Drain-source voltage  $v_{DS}$  and drain current  $i_D$  in the 5 MHz class-E amplifier (PSPICE simulation): (a) full supply voltage  $V_{DD} = 12$  V; (b) reduced supply voltage  $V_{DD} = 1$  V.

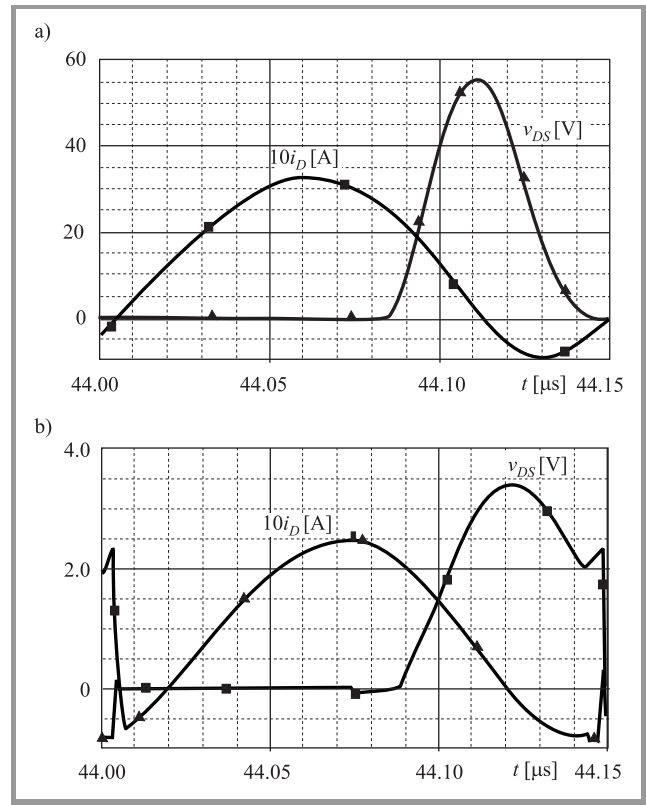

Fig. 9. Drain-source voltage  $v_{DS}$  and drain current  $i_D$  in the 7 MHz class-E amplifier (PSPICE simulation): (a) full supply voltage  $V_{DD} = 12$  V; (b) reduced supply voltage  $V_{DD} = 1$  V.

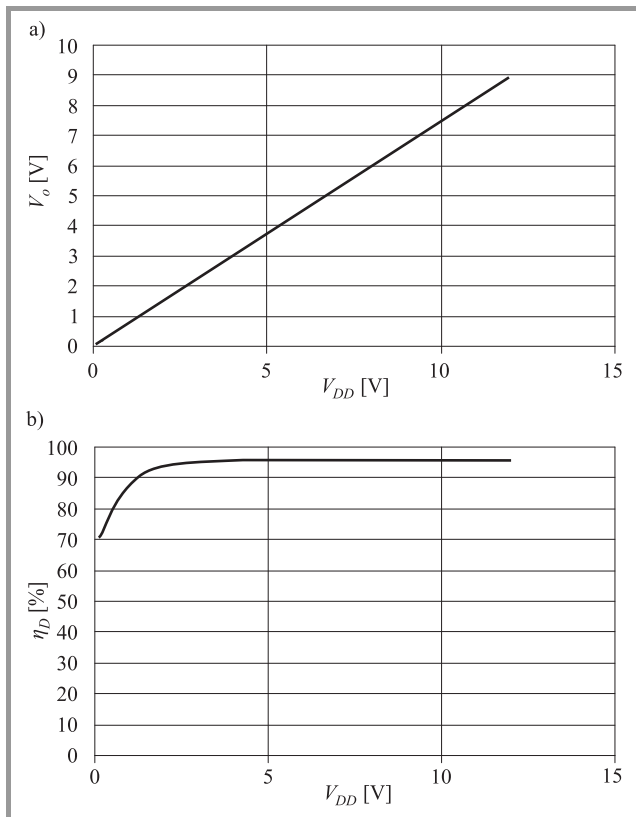

Fig. 8. Characteristic curves (a)  $V_o(V_{DD})$  and (b)  $\eta_D(V_{DD})$  of the 5 MHz class-E amplifier obtained by PSPICE simulations.

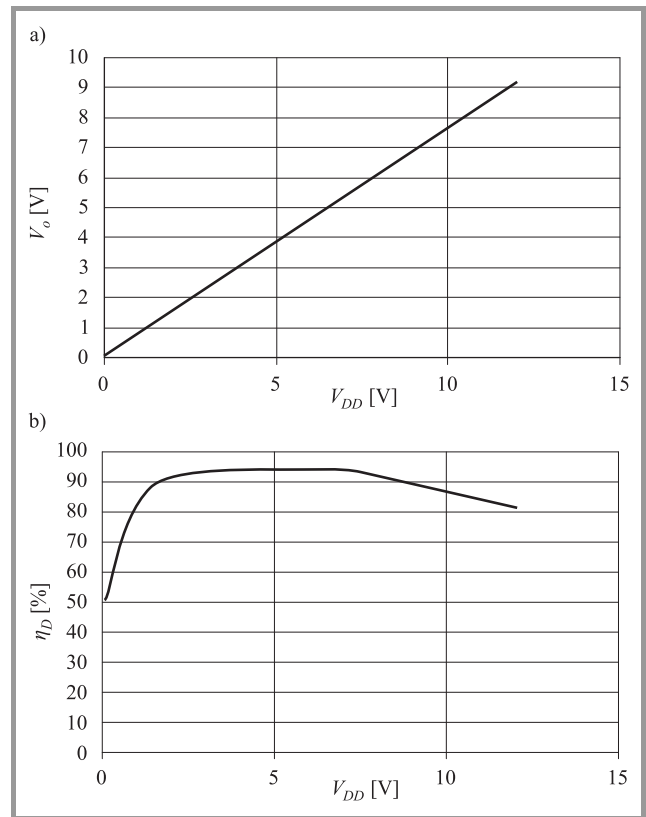

Fig. 10. Characteristic curves (a)  $V_o(V_{DD})$  and (b)  $\eta_D(V_{DD})$  of the 7 MHz class-E amplifier obtained by PSPICE simulations.

the non-ZVS operation appears already for  $V_{DD} \leq 6$  V. It should be noted that in the 7 MHz amplifier for the sufficiently low  $V_{DD}$  the transistor turns on in very adverse conditions: at  $v_{DS} \gg V_{DD}$  (Fig. 9b). Therefore the efficiency of the 7 MHz class-E amplifier decreases significantly with the supply voltage.

To determine the drain-modulation static characteristic curve  $V_o(V_{DD})$  and drain-efficiency static characteristic curve  $\eta_D(V_{DD})$  the PSPICE simulations were carried out for  $V_{DD} = 0, 0.1, 0.3$  V and from  $V_{DD} = 0.5$  V to 12 V every 0.5 V for each amplifier. The obtained results show that the curves  $V_o(V_{DD})$  and  $\eta_D(V_{DD})$  of the 0.5 MHz class-E amplifier (Fig. 6) are almost perfectly linear with a nearly constant slope:  $V_o/V_{DD} \in [0.696, 0.714]$  for  $V_{DD} \in [0.1$  V, 12 V],  $\eta_D \in [97.44\%, 97.90\%]$  for  $V_{DD} \in [0.3$  V, 12 V].

For the 5 MHz amplifier, the characteristic curve  $V_o(V_{DD})$  is acceptable: the ratio  $V_o/V_{DD}$  increases from 0.681 for  $V_{DD} = 1$  V to 0.744 for  $V_{DD} = 12$  V (Fig. 8a). Typical non-linearity can be observed for  $V_{DD} < 1$  (similarly as in [3]). Unfortunately, efficiency of the 5 MHz amplifier decreases from about 95% for  $V_{DD} > 2$  V to 70.5% for  $V_{DD} = 0.1$  V (Fig. 8b).

For the 7 MHz class-E amplifier non-linearity of the characteristic curve  $V_o(V_{DD})$  is higher (Fig. 10a) but harmonic distortion of the AM-signal envelope caused by this non-linearity is acceptable (THD = 1.64% for full drive). In contrast, the efficiency characteristic  $\eta_D(V_{DD})$  of the 7 MHz amplifier (Fig. 10b) is not so good, because efficiency of this amplifier decreases sharply with supply voltage (for  $V_{DD} < 3$  V). Additionally, its efficiency decrease considerably also for  $V_{DD} > 7$  V.

## 6. Experimental Results

A class-E 12 W/0.5 MHz amplifier (Table 1) was built to verify experimentally the influence of non-linear output capacitance of the transistor on the circuit operation. The measured waveforms of currents and voltages in the amplifier are presented in Fig. 11 for two values of the supply voltage:  $V_{DD} = 12$  V and  $V_{DD} = 1$  V. It can be noticed that the drain voltage and current waveforms measured for  $V_{DD} = 12$  V are in a very good agreement with the PSPICE-simulation results (Fig. 5a). The amplifier operates in the optimum mode and the measured efficiency is high (96%) although it is limited by finite quality factor of the applied coil  $L_{sr} = 11.4$   $\mu$ H with ferrite core.

In contrast, for the very low supply voltage  $V_{DD} = 1$  V only the measured waveform of  $v_{DS}$  is exactly compatible with the simulation result (Figs. 11b and 5b). The output capacitance  $C_{oss}$  of the transistor is large but the total shunt capacitance of the switch increases only a little (Fig. 2, Table 1). Therefore the transistor turns on at non-zero but very low voltage and the measured efficiency of the amplifier is still high (93%). The measured drain-modulation static characteristic curve  $V_o(V_{DD})$  of the amplifier is perfectly linear. Unfortunately in the measured wave-

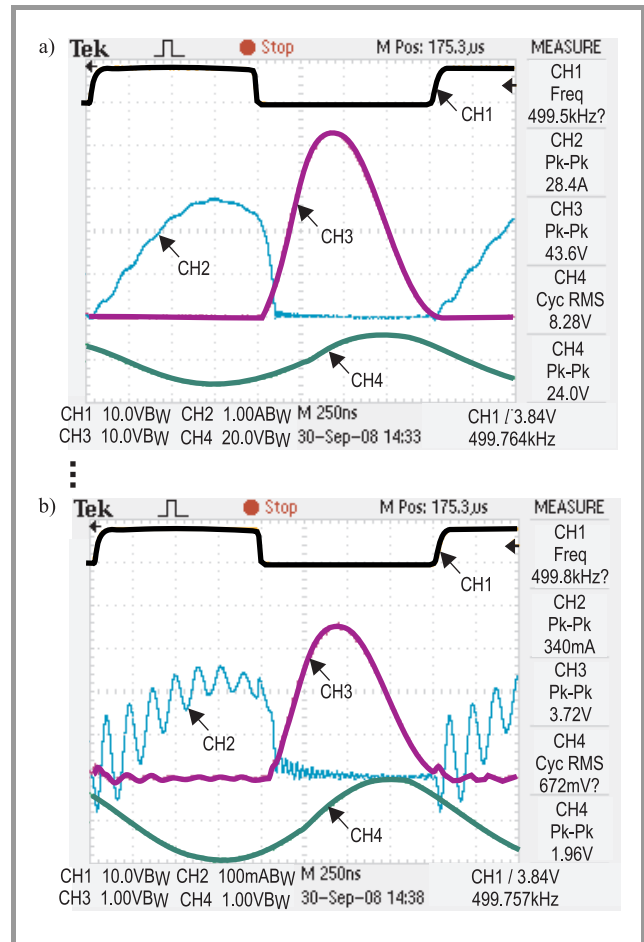

**Fig. 11.** Waveforms measured in 12 W/0.5 MHz class-E amplifier: (a)  $V_{DD} = 12$  V (CH1 – 10 V/div. –  $v_{GS}$ , CH2 – 1 A/div. –  $i_D$ , CH3 – 10 V/div. –  $v_{DS}$ , CH4 – 20 V/div. –  $v_o$ ); (b)  $V_{DD} = 1$  V (CH1 – 10 V/div. –  $v_{GS}$ , CH2 – 100 mA/div. –  $i_D$ , CH3 – 1 V/div. –  $v_{DS}$ , CH4 – 1 V/div. –  $v_o$ ).

form of  $i_D$  high-level parasitic oscillations are observed (Fig. 11b). These oscillations result from the use of the current probe necessary to measure the drain current. The current probe requires connecting a short wire in series with the drain electrode of the transistor, which effectively introduces a series parasitic inductance in the circuit. This effect makes difficult the experimental verification for the class-E amplifiers operating at 5 and 7 MHz in which the parasitic inductance caused by the current probe significantly distorts the non-optimum, sub-optimum and even the optimum operation. Therefore the measurement of the class-E amplifiers operating at 5 MHz and 7 MHz will be a subject of separate research. However, the measured characteristics  $V_o(V_{DD})$ ,  $\eta(V_{DD})$  of built 5 MHz and 7 MHz class-E amplifiers are very close to the simulation results (Figs. 8 and 10).

## 7. Conclusions

Simulated results obtained for class-E amplifiers operating at 0.5 MHz, 5 MHz and 7 MHz have shown that all

the amplifiers can be applied in power amplitude modulators. The non-linear output capacitance of the transistor in the class-E amplifier does not cause significant distortions of the output-signal envelope in such modulators. However, at high operating frequencies when the transistor non-linear output capacitance becomes a major part of the amplifier shunt capacitor a significant reduction of amplifier power efficiency has been observed for both low and high values of the supply voltage. This phenomenon results from the fact that the range of change of the non-linear transistor output capacitance during operation of the class-E amplifier increases significantly with the supply voltage. Therefore normalized current and voltage waveforms of the class-E amplifier without external shunt capacitance depend on its supply voltage. Thus, the class-E amplifier tuned at a given supply voltage (ensuring ZVS and ZCS turn on) is mis-tuned for other values of the supply voltage, which is an important issue in HF AM modulators. The problem will be a subject of further research.

### References

[1] M. Albulet and S. Radu, "Second order effects in collector amplitude modulation of class E power amplifier", *Int. J. Electron. Commun. (AEU)*, vol. 49, no. 1, pp. 44–49, 1995.

[2] R. E. Zulinski and J. W. Steadman, "Class E power amplifiers and frequency multipliers with finite dc-feed inductance", *IEEE Trans. Circ. Syst.*, vol. CAS-34, no. 9, pp. 1074–1087, 1987.

[3] M. K. Kazimierzuk, "Collector amplitude modulation of the class E tuned power amplifier", *IEEE Trans. Circ. Syst.*, vol. CAS-31, no. 6, pp. 543–549, 1984.

[4] "Power MOSFET catalogue", International Rectifier.

[5] M. K. Kazimierzuk and D. Czarkowski, *Resonant Power Converters*. New York: Wiley, 1995.

[6] M. K. Kazimierzuk and K. Puczko, "Exact analysis of class E tuned power amplifier at any Q and switch duty cycle", *IEEE Trans. Circ. Syst.*, vol. CAS-34, no. 2, pp. 149–159, 1987.

[7] M. J. Chudobiak, "The use of parasitic nonlinear capacitors in class E amplifiers", *IEEE Trans. Circ. Syst. I, Fundam. Theory Appl.*, vol. 41, no. 12, pp. 941–944, 1994.

[8] P. Alinikula, K. Choi, and S. Long, "Design of class E power amplifier with nonlinear parasitic output capacitance", *IEEE Trans. Circ. Syst. II, Anal. Dig. Sig. Process.*, vol. 46, no. 2, pp. 114–119, 1999.

[9] T. Suetsugu and M. K. Kazimierzuk, "Comparison of class-E amplifier with nonlinear and linear shunt capacitance", *IEEE Trans. Circ. Syst. I, Fundam. Theory Appl.*, vol. 50, no. 8, pp. 1089–1097, 2003.

[10] T. Suetsugu and M. K. Kazimierzuk, "Analysis and design of class E amplifier with shunt capacitance composed of nonlinear and linear capacitance", *IEEE Trans. Circ. Syst. I, Fundam. Theory Appl.*, vol. 51, no. 7, pp. 1261–1268, 2004.

[11] "Library of power MOSFET models", OrCAD, Inc., 1998.

[12] J. Modzelewski and M. Mikołajewski, "Class-E tuned amplifiers in power amplitude modulators", in *Proc. XVII Int. Conf. Microw. Radar Wirel. Commun. MIKON 2008*, Wrocław, Poland, 2008, vol. 3, pp. 721–724.

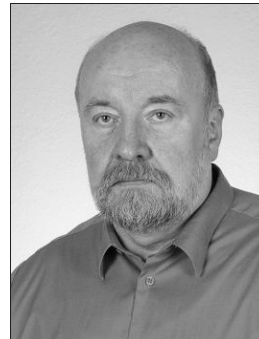

**Juliusz Modzelewski** was born in Warsaw, Poland, in 1953. He received the M.Sc. and Ph.D. degrees in electronics engineering from the Department of Electronics, Warsaw University of Technology in 1977 and 1993, respectively. Since 1977 he has been working in the Institute of Radioelectronics, Warsaw University of Technology (as an Assistant from 1977 to 1993 and as an Assistant Professor from 1993). His teaching, research and development activities are in RF power technology, radio transmitters, and HF high-efficiency power amplifiers.

e-mail: [juliuszm@ire.pw.edu.pl](mailto:juliuszm@ire.pw.edu.pl)  
 Institute of Radioelectronics  
 Warsaw University of Technology  
 Nowowiejska st 15/19  
 00-665 Warsaw, Poland



**Mirosław Mikołajewski** was born in Warsaw, Poland, in 1961. He received his M.Sc. and Ph.D. degrees from the Warsaw University of Technology in 1987 and 1993, respectively, both in electronics engineering. Since 1988 he has been with Warsaw University of Technology, where he currently holds the position of an Assistant Professor. His field of interest covers resonant HF high-efficiency amplifiers as well as switch-mode DC/DC converters.

e-mail: [M.Mikolajewski@ire.pw.edu.pl](mailto:M.Mikolajewski@ire.pw.edu.pl)  
 Institute of Radioelectronics  
 Warsaw University of Technology  
 Nowowiejska st 15/19  
 00-665 Warsaw, Poland